

GZR Gerade Reduzierung mit Dichtkegel

EO 24° DKO Dichtkegel

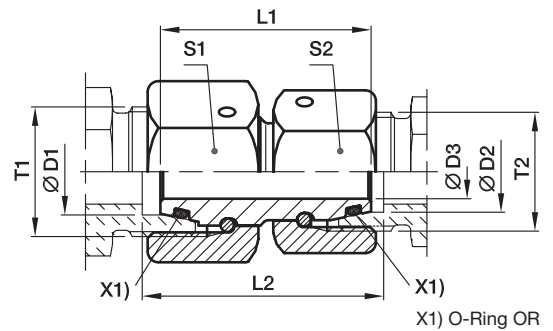

Bau-Reihe 3) 4)	D1	D2	T1	T2	D3	L1	L2	S1	S2	Gewicht g/1 St.	Bestellzeichen*	PN (bar) ¹⁾	
												Stahl	71
L/S	06	06	M 14×1.5	M 12×1.5	2.5	32.5	33.0	17	14	34	GZR06L/06S	500	500
L	08	06	M 14×1.5	M 12×1.5	2.5	33.0	33.0	17	14	36	GZR08L/06L	500	500
L/S	08	08	M 16×1.5	M 14×1.5	4.0	32.5	34.0	19	17	48	GZR08L/08S	500	500
L	10	06	M 16×1.5	M 12×1.5	2.5	34.0	34.0	19	14	44	GZR10L/06L	500	500
L	10	08	M 16×1.5	M 14×1.5	4.0	34.0	34.0	19	17	50	GZR10L/08L	500	500
L/S	10	10	M 18×1.5	M 16×1.5	6.0	34.0	34.5	22	19	63	GZR10L/10S	500	500
L	12	06	M 18×1.5	M 12×1.5	2.5	34.0	34.0	22	14	56	GZR12L/06L	400	400
L	12	08	M 18×1.5	M 14×1.5	4.0	34.0	34.0	22	17	62	GZR12L/08L	400	400
L	12	10	M 18×1.5	M 16×1.5	6.0	34.0	34.0	22	19	65	GZR12L/10L	400	400
L/S	12	12	M 20×1.5	M 18×1.5	8.0	36.5	37.5	24	22	85	GZR12L/12S	400	400
L	15	08	M 22×1.5	M 14×1.5	4.0	39.0	39.0	27	17	98	GZR15L/08L	400	400
L	15	10	M 22×1.5	M 16×1.5	6.0	39.0	39.0	27	19	101	GZR15L/10L	400	400
L	15	12	M 22×1.5	M 18×1.5	8.0	39.0	39.0	27	22	108	GZR15L/12L	400	400
L	18	10	M 26×1.5	M 16×1.5	6.0	37.0	37.5	32	19	125	GZR18L/10L	400	400
L	18	12	M 26×1.5	M 18×1.5	8.0	36.5	37.5	32	22	132	GZR18L/12L	400	400
L	18	15	M 26×1.5	M 22×1.5	10.0	38.5	38.5	32	27	155	GZR18L/15L	400	400
L/S	18	16	M 26×1.5	M 24×1.5	11.0	39.0	39.0	32	30	177	GZR18L/16S	400	400
L	22	12	M 30×2.0	M 18×1.5	8.0	42.5	43.5	36	22	195	GZR22L/12L	250	250
L	22	15	M 30×2.0	M 22×1.5	10.0	42.5	43.5	36	27	215	GZR22L/15L	250	250
L	22	18	M 30×2.0	M 26×1.5	13.0	42.0	44.0	36	32	228	GZR22L/18L	250	250
L/S	22	20	M 30×2.0	M 30×2.0	14.0	44.0	47.0	36	36	266	GZR22L/20S	250	250
L	28	15	M 36×2.0	M 22×1.5	10.0	46.5	47.5	41	27	143	GZR28L/15L	250	250
L	28	18	M 36×2.0	M 26×1.5	13.0	39.5	48.0	41	32	311	GZR28L/18L	250	250
L	28	22	M 36×2.0	M 30×2.0	17.0	46.0	46.0	41	36	309	GZR28L/22L	250	250
L/S	28	25	M 36×2.0	M 36×2.0	18.0	46.0	50.5	41	46	419	GZR28L/25S	250	250
L	35	18	M 45×2.0	M 26×1.5	13.0	48.0	51.0	50	32	430	GZR35L/18L	250	250
L	35	22	M 45×2.0	M 30×2.0	17.0	48.0	51.0	50	36	429	GZR35L/22L	250	250
L	35	28	M 45×2.0	M 36×2.0	22.0	48.0	51.0	50	41	415	GZR35L/28L	250	250
L/S	35	30	M 45×2.0	M 42×2.0	23.0	52.0	59.0	50	50	577	GZR35L/30S	250	250
L	42	22	M 52×2.0	M 30×2.0	17.0	52.0	55.5	60	36	653	GZR42L/22L	250	250
L	42	28	M 52×2.0	M 36×2.0	22.0	52.0	55.5	60	41	648	GZR42L/28L	250	250
L	42	35	M 52×2.0	M 45×2.0	28.0	52.0	56.5	60	50	662	GZR42L/35L	250	250
L/S	42	38	M 52×2.0	M 52×2.0	30.0	52.0	62.0	60	60	822	GZR42L/38S	250	250
S	08	06	M 16×1.5	M 14×1.5	2.5	33.0	34.0	19	17	49	GZR08L/06S	800	800
S	10	06	M 18×1.5	M 14×1.5	2.5	33.0	34.5	22	17	60	GZR10L/06S	800	800
S	10	08	M 18×1.5	M 16×1.5	4.0	33.0	34.5	22	19	66	GZR10L/08S	800	800
S	12	06	M 20×1.5	M 14×1.5	2.5	36.0	37.5	24	17	77	GZR12L/06S	630	630
S	12	08	M 20×1.5	M 16×1.5	4.0	36.0	37.5	24	19	82	GZR12L/08S	630	630
S	12	10	M 20×1.5	M 18×1.5	6.0	36.0	38.0	24	22	89	GZR12L/10S	630	630
S	16	10	M 24×1.5	M 18×1.5	6.0	39.0	41.5	30	22	138	GZR16L/10S	630	630
S	16	12	M 24×1.5	M 20×1.5	8.0	39.0	41.5	30	24	143	GZR16L/12S	630	630
S/L	16	15	M 24×1.5	M 22×1.5	10.0	39.5	41.5	30	27	153	GZR16S/15L	400	400
S	20	12	M 30×2.0	M 20×1.5	8.0	44.0	47.0	36	24	204	GZR20L/12S	420	420

GZR Gerade Reduzierung mit Dichtkegel

EO 24° DKO Dichtkegel

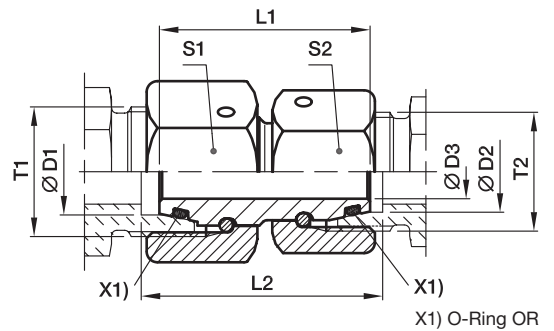

X1) O-Ring OR

Bau-Reihe 3) 4)	D1	D2	T1	T2	D3	L1	L2	S1	S2	Gewicht g/1 St.	Bestellzeichen*	PN (bar) ¹⁾	
												Stahl	71
S	20	16	M 30×2.0	M 24×1.5	11.0	44.0	47.5	36	30	232	GZR20/16S	420	420
S/L	20	18	M 30×2.0	M 26×1.5	13.0	44.0	47.0	36	32	224	GZR20S/18L	400	400
S	25	16	M 36×2.0	M 24×1.5	11.0	46.0	51.0	46	30	224	GZR25/16S	420	420
S	25	20	M 36×2.0	M 30×2.0	14.0	46.0	51.5	46	36	364	GZR25/20S	420	420
S/L	25	22	M 36×2.0	M 30×2.0	17.0	46.0	50.5	46	36	475	GZR25S/22L	250	250
S	30	16	M 42×2.0	M 24×1.5	11.0	52.0	58.5	50	30	475	GZR30/16S	420	420
S	30	20	M 42×2.0	M 30×2.0	14.0	52.0	59.0	50	36	500	GZR30/20S	420	420
S	30	25	M 42×2.0	M 36×2.0	18.0	52.0	60.5	50	46	589	GZR30/25S	420	420
S/L	30	28	M 42×2.0	M 36×2.0	22.0	52.0	58.0	50	41	476	GZR30S/28L	250	250
S	38	20	M 52×2.0	M 30×2.0	14.0	52.0	61.5	60	36	671	GZR38/20S	420	420
S	38	25	M 52×2.0	M 36×2.0	18.0	52.0	63.0	60	46	759	GZR38/25S	420	420
S	38	30	M 52×2.0	M 42×2.0	23.0	52.0	64.5	60	50	767	GZR38/30S	420	420
S/L	38	35	M 52×2.0	M 45×2.0	28.0	52.0	61.5	60	50	662	GZR38S/35L	250	250

1) Druckwert genannt = Artikel lieferbar

3) L = Leichte Baureihe: 4) S = Schwere Baureihe

$$\frac{PN \text{ (bar)}}{10} = PN \text{ (MPa)}$$

Hinweise zum Bestellen von alternativen Dichtungsmaterialien
siehe Seite 17.

Bestellzeichen-Ergänzungen			
Material	Kennbuchstaben Oberfläche und Material	Beispiel	Standard-Dichtungswerkstoff (keine zusätzl. Kennbuchstaben erforderlich)
Stahl	CF	GZR16/12SCF	NBR
Edelstahl	71	GZR16/12S71	VIT

*Ergänzen Sie bitte die Bestellzeichen mit den für das gewünschte Material.