

# Snap-tite 71 Series

High Pressure, Push-to-Connect  
Non-Spill Quick Couplings



## Heavy Duty with Superior Flow and Versatility

Parker's Snap-tite 71 Series couplings are designed for working pressures up to 690 bar. Available in a variety of materials and with a wide range of body sizes.

Air inclusion and fluid loss are minimal with the flush face valves. Large flow chambers in the body and an exclusive valve design permit superior flow while maintaining low pressure drop.



## Contact Information: 71 Series Features:

Parker Hannifin Manufacturing  
Sweden AB  
**Quick Coupling Division Europe**  
Västra Skogsrovägen 1  
54106 Skövde – Sweden

phone +46 500 44 36 00  
fax +46 500 44 36 20  
tema-rfq@parker.com

[www.parker.com](http://www.parker.com)

- Flush face/dry break
- Push-to-connect
- Heavy duty construction
- Designed for up to 690 bar working pressures
- Variety of materials
- Wide range of sizes
- Superior flow and low pressure drop
- Sleeve lock design to protect against accidental disconnection
- Available with Autoclave cone and threaded fittings



ENGINEERING YOUR SUCCESS.

# Technical and Dimensional Information

Size: 1/4" thru 1-1/4"

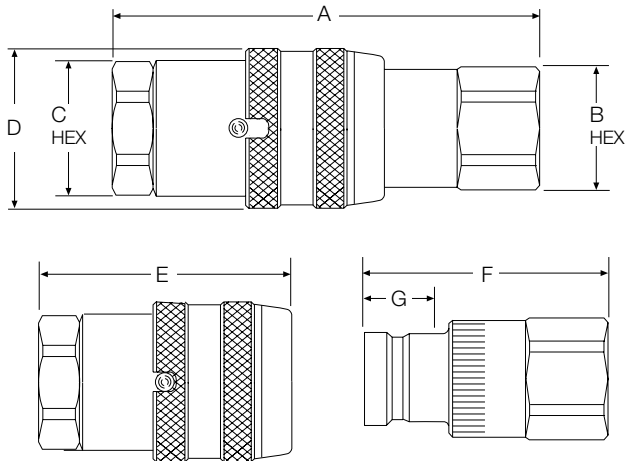

Size	A mm	B (Hex) <sup>1</sup> mm	C (Hex) <sup>*</sup> mm	D (Ø) <sup>1</sup> mm	E mm	F mm	G mm
1/4"	83,06	20,57	23,88	30,23	49,78	46,74	13,46
3/8"	101,60	25,40	30,23	39,62	59,95	58,93	17,27
1/2"	112,52	38,10	38,10	47,75	70,36	60,45	18,29
3/4"	130,30	44,45	44,45	57,15	77,47	75,18	22,35
1"	142,24	47,75	50,80	66,80	84,33	82,04	24,13
1 1/4"	157,99	50,80	50,80	66,80	93,22	88,90	24,13

<sup>1</sup> Hex dimensions are taken from flat of hex and not across corners. Hex may be substituted with round stock.

Hex column would then indicate dimension taken across wrench flats. Decimal dimensions are ± 1.5mm.

Part configurations are typical and do not necessarily represent actual appearance.

**Note:** 1/4" thru 1-1/4" are flush face couplings. 1-1/2" & 2" maintain a recessed face on coupler half.

Size	Spillage (cc)	Air Inclusion (cc)	Steel				316 Stainless Steel				High Pressure Stainless Steel			
			Max. Working PSI	bar	Min. Burst <sup>5</sup> PSI	bar	Max. Working PSI	bar	Min. Burst <sup>5</sup> PSI	bar	Max. Working PSI	bar	Min. Burst <sup>5</sup> PSI	bar
1/4"	0,02	0,01	10.000	690	20.000	1.379	5.000	344	12.500	862	10.000	690	20.000	1.379
3/8" x 1/4" <sup>2</sup>	0,02	0,02	10.000	690	20.000	1.379	5.000	344	12.500	862	10.000	690	20.000	1.379
3/8"	0,02	0,02	10.000	690	20.000	1.379	5.000	344	12.500	862	10.000	690	20.000	1.379
3/8" x 1/2" <sup>3</sup>	0,02	0,02	10.000	690	20.000	1.379	5.000	344	12.500	862	10.000	690	20.000	1.379
1/2"	0,03	0,03	10.000	690	20.000	1.379	5.000	344	12.500	862	10.000	690	20.000	1.379
3/4"	0,06	0,04	7.500	517	15.000	1.034	5.000	344	12.500	862	7.500	517	15.000	1.034
1"	0,10	0,06	7.500	517	15.000	1.034	4.000	275	10.000	690	7.500	517	15.000	1.034
1" x 1 1/4" <sup>4</sup>	0,10	0,06	7.500	517	15.000	1.034	4.000	275	10.000	690	7.500	517	15.000	1.034

<sup>2</sup> Unit is 3/8" with 1/4" endfitting / <sup>3</sup> Unit is 3/8" with 1/2" endfitting / <sup>4</sup> Unit is 1" with 1 1/4" endfitting.

<sup>5</sup> Note: Pressure Ratings were established under static pressure conditions. For high impulse applications, please contact your Parker sales team.

## Flow Chart

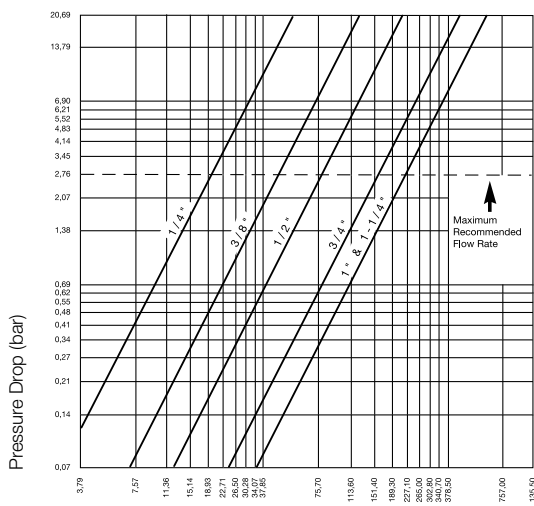

Flow Rate in l/min

Test Media MIL-H-6083 Hydraulic Fluid at +32°C ± 1.5°C sg .83

# Technical and Dimensional Information

Size: 1 1/2" and 2"

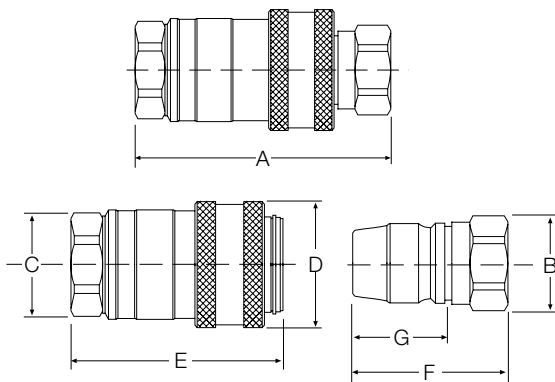

Size	A mm	B (Hex) <sup>1</sup> mm	C (Hex) <sup>1</sup> mm	D (Ø) <sup>1</sup> mm	E mm	F mm	G mm
1 1/2"	193,04	82,55	85,85	114,30	157,73	114,30	81,53
2"	193,04	82,55	85,85	114,30	157,73	118,20	81,53

<sup>1</sup> Hex dimensions are taken from flat of hex and not across corners. Hex may be substituted with round stock.

Hex column would then indicate dimension taken across wrench flats. Decimal dimensions are ± 1.5mm.

Dimensions are subject to change without notice.

Part configurations are typical and do not necessarily represent actual appearance.

**Note:** 1/4" thru 1-1/4" are flush face couplings. 1-1/2" & 2" maintain a recessed face on coupler half.

Size	Spillage (cc)	Air Inclusion (cc)	Steel				316 Stainless Steel				High Pressure Stainless Steel			
			Max. Working PSI	bar	Min. Burst <sup>3</sup> PSI	bar	Max. Working PSI	bar	Min. Burst <sup>3</sup> PSI	bar	Max. Working PSI	bar	Min. Burst <sup>3</sup> PSI	bar
2" x 1 1/2" <sup>2</sup>	5,25	30,50	5.000	344	10.000	690	3.000	206	6.000	413	5.000	344	10.000	690
2"	5,25	30,50	5.000	344	10.000	690	3.000	206	6.000	413	5.000	344	10.000	690

<sup>2</sup> Unit is 2" with 1 1/2" endfittig.

<sup>3</sup> Note: Pressure Ratings were established und static pressure conditions. For high impulse applications, please contact your Parker sales team.

## Flow Chart

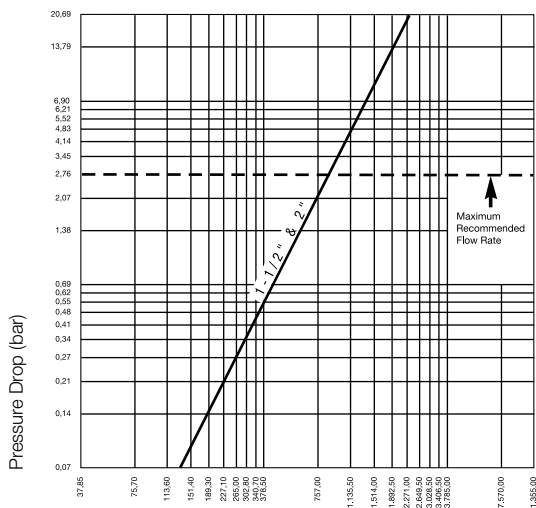

Flow Rate in l/min

Test Media MIL-H-6083 Hydraulic Fluid at +32°C ± 1.5°C sg .83

## Plastic Dust Caps

Size	Coupler Dust Cap 71-3 Style	Nipple Dust Cap 71-3 Style
1/4"	71-3PCC-4	71-3PNC-4
3/8"	71-3PCC-6	71-3PNC-6
1/2"	71-3PCC-8	71-3PNC-8
3/4"	71-3PCC-12	71-3PNC-12
1"	71-3PCC-16	71-3PNC-16

## Maximum Recommended Connect / Disconnect Pressures

Size	Pressure	
	PSI	bar
1/4"	300	21
3/8", 1/2", 3/4"	150	11
1", 1 1/4"	75	5
1 1/2", 2"	0	0

## Ordering Information

**71-3 C 4 - 4 F**

**Coupling Body Size:**  
 4 = 1/4"    12 = 3/4"  
 6 = 3/8"    16 = 1"  
 8 = 1/2"    32 = 2"

**End Fitting Size:**  
 4 = 1/4"    16 = 1"  
 6 = 3/8"    20 = 1-1/4"  
 8 = 1/2"    24 = 1-1/2"  
 12 = 3/4"    32 = 2"

**End Fitting Type:**  
 F = Female NPTF  
 EF = Female SAE  
 RP = Female British Parallel BS2779  
 Autoclave cone & threaded fittings available (consult QCDE)

**Coupling Half:**  
 C = Coupler  
 N = Nipple

**Series:**  
 71 = 1-1/2" & 2" Nipples Only  
 71-1 = 1-1/2" & 2" Couplers Only  
 71-3 = 1/4" thru 1-1/4" both

**Material:**  
 Blank = Steel, zinc trivalent plating  
 S = 316 Stainless Steel  
 SH = High Pressure Stainless Steel

**Seals:**  
 Standard Seal = NBR  
 V = FKM  
 E = EPDM  
 M = MHO

**Options:**  
 SL = Sleeve Lock

### Notes:

- For sizes up to 1" NPTF threads in steel
- For sizes up to 1" NPSF threads in stainless steel
- For sizes over 1" NPT threads
- The current 71-3 couplers and nipples are interchangeable with previous design couplers and nipples in sizes 3/8", 1/2" and 3/4".
- Replacement part kits are available for all styles in sizes 1/4" through 2".
- Internal components of S and SH style 71 Series are not all 316 grade stainless steel. Consult QCDE for details.
- Not all configurations are standard product offering. Contact QCDE for price and delivery.

