

Pneumatic spindles
Pneumatic built-in motors



MANNESMANN DEMAG

Always one step ahead



Intelligent solutions to save time and costs

As an insider you know that being at the cutting edge of automation is crucial in special machine construction. When installing MANNESMANN DEMAG pneumatic spindles and build-in motors you can be sure that state-of-the-art technology, maximum reliability and serious top-rate quality will bring the key advantages to your automation process.

Precision is trumps. This is why our spindles work with an extremely high true-running accuracy of less than 0.02 mm.

Durability pays off. Housings and spindles are made of extra-robust stainless steel. So you can look forward to particularly long tool life: thanks to floating bearing support for turbine spindles by MANNESMANN DEMAG, and thanks to paired bearings for all other built-in spindles.

Deburring, drilling, brushing, sanding, milling. Optimum surface quality is guaranteed when processing your workpieces.

Metals and other materials. The high-speed spindles from our product range allow for a high cutting speed. The corresponding tools are capable of processing both metallic and also non-metallic materials.



The MANNESMANN DEMAG full service offer:

- Professional know-how and reliable quality
- Increased long-time tool life
- Maintenance: no need for stocks of spares
- Mature innovative solutions for milling, sanding, drilling, brushing and polishing
- Reduced repair costs: low costs for spare parts
- Total transparency: we register and document all maintenance and repairs for you



Reduce your costs now!

Just contact us, we'll optimise your previous solution, whether individual product or all-in system.

You can approach us without obligation, our service adviser will contact you immediately:

+49 711 887 18-0 or
info@mannesmann-demag.com

Pneumatic spindles

Non-lubricated turbines



EST 1000 ZG

EST 1000 K | EST 650 K

Technical data

Type		EST 1 000 ZG	EST 1 000 K	EST 650 K	EST 450 K
Order-No.		Blade wheel turbine 29924-61-7	Jet turbine 29939-57-7	Jet turbine 29939-58-7	Jet turbine 60016-67-5
Free speed	rpm	100 000	100 000	65 000	45 000
Motor power	Watt	100	100	100	160
Direction of rotation		clockwise	clockwise	clockwise	clockwise
Exhaust air		to the front	to the rear	to the rear	to the rear
Collet included	mm	3	3	3	6
Collets available	mm	1.0 1.5 2.0 2.5 3/32" 1/8"	1.0 1.5 2.0 2.5 3/32" 1/8"	1.0 1.5 2.0 2.5 3/32" 1/8"	3.0 4.0 5.0
Carbide burrs	max. mm	3	3	3	8
Mounted points and wheels	max. mm	5	5	5	10
Noise level	dB(A)	74	69	69	74
Air consumption	l/sec	5.3	3.5	3.5	7 15
Weight	kg	0.25	0.26	0.26	1.6
Connection air supply (hose)	Ø mm, inside/outside	2.7 4	6 8	6 8	8 -

Power and free speed at 6 bar operating pressure. Compressed air quality: absolutely non-lubricated.

- For installation in transfer lines, machine tools and robot stations
- Stainless steel housings
- Stainless steel spindles
- Floating bearings
- High speeds for excellent processing quality
- Maintenance-friendly
- High true-running accuracy for long tool lives
- EST 650 and 450: centrifugal governor



ES 852 ZG



ES 550 ZG

Technical data

Type		ES 852 ZG	ES 550 ZG
Order-No.		29944-30-7	29924-59-7
Free speed	rpm	80 000	55 000
Motor power	Watt	100	100
Direction of rotation		clockwise	clockwise
Exhaust air		to the rear	to the rear
Collet included	mm	3	3
Collets available	mm	1.0 1.5 2.0 2.5 3/32 " 1/8 "	1.0 1.5 2.0 2.5 3/32 " 1/8 "
Carbide burrs	max. mm	4	4
Mounted points and wheels	max. mm	6	6
Noise level	dB(A)	84	75
Air consumption	l / sec	2.3	2.3
Weight	kg	0.11	0.08
Connection air supply (hose)	∅ mm, inside /outside	4 6	4 6

Power and free speed at 6 bar operating pressure. Compressed air quality: lubricated (2–3 drops per minute).

- For installation in transfer lines, machine tools and robot stations
- Stainless steel housings
- Stainless steel spindle
- Small dimensions
- High true-running accuracy
- Overload capacity 100 %
- ES 852 ZG: Paired bearings for increased tool life and better running properties
- ES 852 ZG: with splashguard

Pneumatic spindles



ES 450 ER

ES 350 ER

Technical data

Type (with ZG collet)		• ES 450 ZG	• ES 350 ZG
Order-No.		60012-12-7	60012-16-7
Type (with ER collet)		• ES 450 ER	• ES 350 ER
Order-No.		60012-13-7	60012-15-7
Free speed	rpm	45 000	35 000
Motor power	Watt	230	300
Direction of rotation *		clockwise	clockwise
Exhaust air **		to the rear	to the rear
• ZG collet included	mm	6	6
• ZG collets available	mm "	3 4 5 1/4"	3 4 5 8 1/4"
• ER collet included	mm	6	6
• ER collets available	mm	3 4 5	3 4 5
Carbide burrs	max. mm	8	10
Mounted points and wheels	max. mm	10	16
Noise level	dB(A)	78	79
Air consumption	l / sec	7.5	8.3
Weight	kg	0.39	0.42
Connection air supply (hose)	Ø mm, inside / outside	6 8	6 8

Power and free speed at 6 bar operating pressure. Compressed air quality: lubricated (2–3 drops per minute).

* Direction of rotation: *counterclockwise* on request | ** Exhaust air: with *guided exhaust air* upon request

- For installation in transfer lines, machine tools and robot stations
- Stainless steel housings
- Stainless steel spindles
- With collet chuck or precision collet chuck
- High true-running accuracy
- Paired bearings for longer tool life time and better running properties
- With splashguard to prevent penetration of dust, water or metal chips



Technical data

Type (with ZG collet)		• ES 280 ZG	• ES 200 ZG	• ES 170 ZG
Order-No.		29924-53-7	60008-31-7	29924-45-7
Type (with ER collet)		• ES 280 ER	• ES 200 ER	• ES 170 ER
Order-No.		29924-52-7	60008-32-7	29924-44-7
Free speed	rpm	28 000	20 000	15 000
Motor power	Watt	380	400	800
Direction of rotation *		clockwise	clockwise	clockwise
Exhaust air **		to the rear	to the rear	to the rear
• ZG collet included	mm	6	6	8
• ZG collets available	mm "	3 5 8 1/4"	3 5 8 1/4"	3 5 6 1/4" 10
• ER collet included	mm	6	6	8
• ER collets available	mm	3 5 8 10	3 5 8 10	3 5 6 10
Carbide burrs	max. mm	10	12	15
Mounted points and wheels	max. mm	16	25	32
Noise level	dB(A)	80	72	86
Air consumption	l/ sec	11.5	8.5	15.8
Weight	kg	0.75	1.10	1.65
Connection air supply (hose)	Ø mm, inside /outside	10 12	10 12	10 12

Power and free speed at 6 bar operating pressure. Compressed air quality: lubricated (2–3 drops per minute).

* Direction of rotation: *counterclockwise* on request | ** Exhaust air: with *guided exhaust air* upon request

- For installation in transfer lines, machine tools and robot stations
- Stainless steel housings
- Stainless steel spindles
- With collet chuck or precision collet chuck
- High true-running accuracy
- Paired bearings for longer tool life time and better running characteristics
- With splashguard to prevent penetration of dust, water or metal chips

Pneumatic built-in motors

With collet



EBM with collet

Technical data

Type with collet (clockwise)		EBM 19000 S	EBM 5200 S	EBM 2900 S	EBM 2400 S	EBM 1200 S
Order-No.		60001-04-7	29937-63-7	29937-61-7	29937-62-7	60003-85-7
Type with collet (counterclockwise)		EBM 19000 SL	EBM 5200 SL	EBM 2900 SL	—	—
Order-No.		29946-52-7	29948-37-7	29948-32-7		
Free speed	rpm	19 000	5 200	2 900	2 400	1 200
Motor power	Watt	380	380	380	380	380
ER collet included	mm	6	6	6	6	6
ER collets available	mm "	3 5 8 10	3 5 8 10	3 5 8 10	3 5 8 10	3 5 8 10
Exhaust air *		to the rear	to the rear	to the rear	to the rear	to the rear
Noise level	dB(A)	72	72	72	72	72
Air consumption	l / sec	8.5	8.5	8.5	8.5	8.5
Weight	kg	1.12	1.12	1.12	1.12	1.42
Connection air supply (hose)	Ø mm, inside / outside	10 12	10 12	10 12	10 12	10 12

Power and free speed at 6 bar operating pressure. Compressed air quality: lubricated (2–3 drops per minute).

* Exhaust air: with *guided exhaust air* upon request

- For installation in transfer lines, machine tools and robot stations
- Stainless steel housings
- Stainless steel spindle for all collet models
- Ideal for **drilling or brushing**
- Without valve for central remote control
- Small housing diameter for minimum centre-to-centre spacing
- Splashguard to prevent penetration of dust, water or metal chips

The suitable accessories: page 67.

Types of exhaust air

- A** The machines are standardly supplied with a sintered plate.
- B** The machines can also be supplied as a guided exhaust air model.
- C** Exemplary drawing of guided air exhaust.
- D** The speed of the machine can be adjusted precisely by using a silencer with an integrated throttle (Order-No. 9361705).
- E** The exhaust air can be cleaned and filtered up to 99% by connecting the machine to an oil trap unit (Order-No. 60025-98-6)

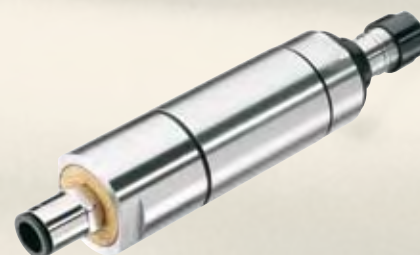

A

Pneumatic built-in motors With drill chuck



Technical data

Type		EBM 38-5200 B	EBM 38-2900 B	EBM 38-2400 B	EBM 38-1200 B	EBM 5000 B	EBM 3500 B
Order-No.		29937-64-7	60009-26-7	60009-25-7	60008-71-7	29937-41-7	60009-24-7
Free speed	rpm	5 200	2 900	2 400	1 200	5 000	3 500
Motor power	Watt	380	380	380	380	160	160
Drill chuck clamping range	mm	1–10	1–10	1–10	1–10	1–6	1–6
DIN cone or thread		3/8" × 24 UNF	3/8" × 24 UNF	3/8" × 24 UNF	3/8" × 24 UNF	B 10	B 10
Direction of rotation		clockwise	clockwise	clockwise	clockwise	clockwise	clockwise
Exhaust air		to the rear	to the rear	to the rear	to the rear	to the rear	to the rear
Noise level	dB(A)	76 *	76 *	76 *	76 *	71	71
Air consumption	l/sec	8.5	8.5	8.5	8.5	5.0	5.0
Weight	kg	1.20	1.20	1.20	1.50	0.62	0.62
Connection thread		G 1/4"	G 1/4"	G 1/4"	G 1/4"	—	—
Connection air supply (hose)	Ø mm, inside/outside	—	—	—	—	6 8	6 8

Power and free speed at 6 bar operating pressure. Compressed air quality: lubricated (2–3 drops per minute).

* With exhaust air throttle: Order-No. 9 361 705

– For installation in transfer lines,
machine tools and robot stations

– Stainless steel housings
– Ideal for **drilling or brushing**
– Without valve for central remote
control

– Small housing diameter for minimum
centre-to-centre spacing
The suitable accessories: page 67.

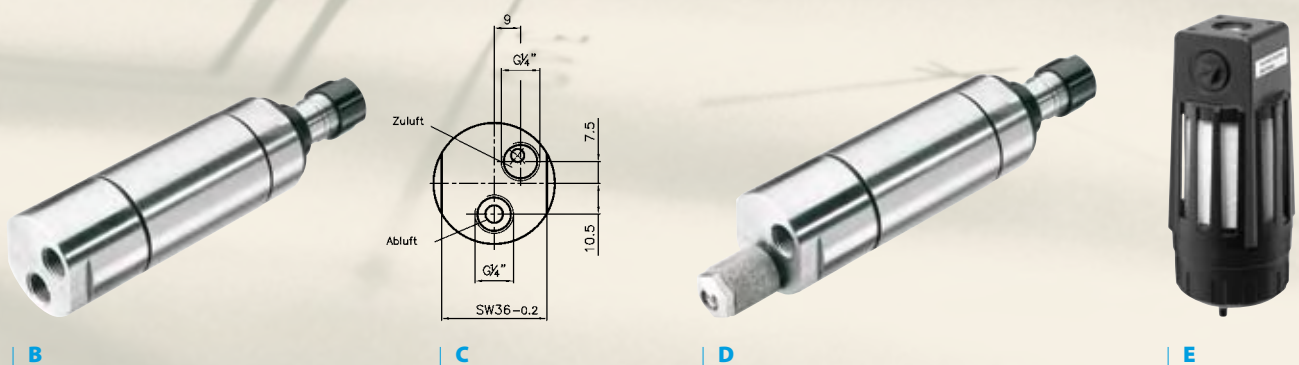

Pneumatic built-in motors

Reversible



EBMU 40

Technical data

Type		EBMU 23-4000 B	EBMU 23-2000 B	EBMU 23-1000 B	EBMU 40-4800 B	EBMU 40-3400 B	EBMU 40-3000 B
Order-No.		60009-28-7	60009-31-7	60009-34-7	60008-19-7	60008-17-7	60008-15-7
Free speed	rpm	4 000	2 000	1 000	4 800	3 400	3 000
Motor power	Watt	230	230	230	550	550	550
Drill chuck clamping range	mm	1 – 10	1 – 10	1 – 10	1 – 10	1 – 10	1 – 10
DIN cone or thread		3/8 " × 24 UNF	3/8 " × 24 UNF	3/8 " × 24 UNF	1/2 " × 20 UNF	1/2 " × 20 UNF	1/2 " × 20 UNF
Direction of rotation		reversible	reversible	reversible	reversible	reversible	reversible
Exhaust air		to the rear	to the rear	to the rear	to the rear	to the rear	to the rear
Noise level	dB(A)	72	72	72	78	78	78
Air consumption	l/sec	7.8	7.8	7.8	15	15	15
Weight	kg	1.25	1.25	1.55	2.6	2.6	2.6
Connection thread		G 1/4 "	G 1/4 "	G 1/4 "	G 1/4 "	G 1/4 "	G 1/4 "

Power and free speed at 6 bar operating pressure. Compressed air quality: lubricated (2–3 drops per minute).

- For installation in transfer lines, machine tools and robot stations
- Stainless steel housings
- Ideal for **brushing**
- Without valve for central remote control

- Small housing diameter for minimum centre-to-centre spacing
- Even wear of brushes through left-/right hand rotation ensures longer lifetime of the brush

The suitable accessories: page 67.



Technical data

Type		EBS 504 ZG	EBS 520 ER	EBS 520 WK	EWBS 38-520
Order-No.		29937-30-7	29938-81-7	60003-50-7	60001-29-5
Free speed	rpm	500	520	520	520
Motor power	Watt	160	380	380	380
Start up		push start	external	external	external
Direction of rotation		clockwise	clockwise	clockwise	clockwise
Exhaust air		to the rear	to the rear	to the rear	to the rear
Holding fixture		—	—	10 mm	1/4"–6 kt.
ZG collet included	mm	8	8	—	—
ZG collets available	mm	5 6 1/4" 10	3 5 6 10	—	—
Radial compliance of coupling		—	—	±7°	—
Radial off-set of coupling	mm	—	—	±0.5	—
Noise level	dB(A)	65	77 *	77 *	76 *
Air consumption	l / sec	5.3	8.5	8.5	8.5
Weight	kg	0.75	1.40	1.20	2.30
Connection air supply (hose)	∅ mm, inside / outside	6 8	10 12	10 12	10 12

Power and free speed at 6 bar operating pressure. Compressed air quality: lubricated (2–3 drops per minute).

* With exhaust air throttle: Order-Nr. 9 361 705

- For installation in transfer lines, machine tools and robot stations
- Stainless steel housings
- Stainless steel spindles
- Ideal for **countersinking and brushing**

- Collets up to 10 mm
- Rotating splashguard to prevent penetration of dust, water or chips (Types EBS 520)
- Push start for EBS 504 reduces air consumption

EBS 520 WK:

- With helix coupling to balance axial / radial tolerances, for chamfering tools with shaft diameter 10 mm

Accessories

HSS counterbore	EWBS 38-520
3 blades, 1/4" hexagon / 90°	
Sinking range 2.5 – 10 mm	48109-21-6
Sinking range 3.2 – 16.5 mm	48109-22-6
Sinking range 5 – 25 mm	48109-24-6

RoboCut | High speed spindles with Weldon shaft For use with quick-release tapers



At highest speed with many advantages:
drilling, engraving, milling, edging, deburring of metals,
plastics, wood and carbonfibre.

Made in Germany

- For use with carbide burrs, gravers and drills
- High true running accuracy for low vibration
- Stainless steel housing
- Can be used in turning machine also
- Perfectly suitable for small parts manufacturing

→ Intelligent use of tools

RoboCut | High speed spindles For use in CNC machine tools



ESK 1000 W20



ESK 350 W20

Technical data

RoboCut		ESK 1 000 W20	ESK 350 W20
Order-No.		60019-58-7	60019-27-7
Air quality		oilfree	with oil
Free speed	rpm	100 000	35 000
Motor power	Watt	100	300
Exhaust air		to the front	to the front
Collet included	mm	3	6
Collets available	mm	1.0 1.5 2.0 2.5 3/32" 1/8"	3.0 4.0 5.0
Turning direction		clockwise	clockwise
Length	mm	165	224
Diameter	mm	30	30
Air consumption	l/sec	5.3	8.3
Weight	kg	1.4	2.5
Hose (Ø inside)	mm	6	6
Accessories		wrench	wrench

Power and free speed at 6 bar operating pressure. Compressed air quality: lubricated (2–3 drops per minute).
Subject to technical alterations without prior notice

ESK 1000 W20

- Oilfree, nearly no wear
- Spindle floating support conserves inserted tools
- Compensation of unbalanced mass
- Precision bearings with steel balls
- Resistant to remaining cooling fluids
- Maximum speed at small design

ESK 350 W20

- High true running accuracy for long continuous operation
- Paired ball bearings with steel balls for long life time
- Powerful vane motor
- Resistant to remaining cooling fluids

RoboCut | High speed spindles

For finishing and high precision deburring



ESR 1000 FW



ESR 855 FW



ESR 551 FW

Technical data

RoboCut		ESR 1 000	ESR 855	ESR 551
Order-No.		60007-42-5	60007-38-5	60007-39-5
RoboCut		ESR 1 000 FW	ESR 855 FW	ESR 551 FW
Order-No.		29948-71-5	29948-67-5	29948-66-5
Compressed air		non-lubricated	lubricated	lubricated
Free speed	rpm	100 000	80 000	55 000
Motor power	Watt	100	100	100
Radial compliance		± 4°	± 4°	± 4°
Exhaust air		to the front	to the front	to the front
ZG collet included	mm	3	3	3
ZG collets available	mm	1.0 1.5 2.0 2.5 3/32" 1/8"	1.0 1.5 2.0 2.5 3/32" 1/8"	1.0 1.5 2.0 2.5 3/32" 1/8"
Pre-adjusted compliance force		5–7 N	5–7 N	5–7 N
Compliance force range *		4–12 N	3–12 N	3–12 N
Direction of rotation		clockwise	clockwise	clockwise
Noise level	dB(A)	70	86	78
Air consumption	l/sec	5.3	2.3	2.3
Weight	kg	0.82	0.66	0.57
Connection air supply (hose)	∅ mm, inside/outside	2.7 4	2.7 4	2.7 4
Accessories supplied		wrench, spring sets	wrench, spring sets	wrench, spring sets

Power and free speed at 6 bar operating pressure. Compressed air quality: lubricated (2–3 drops per minute). Subject to technical alterations.

* ESR 1 000, ESR 855, ESR 551: Compliance force is set by precision pressure regulator.

All types

- High true-running accuracy for long endurance running
- High revolution speed for excellent surface finishing

ESR 1 000 FW, ESR 855 FW, ESR 551 FW

- Different compliance forces by simply changing the springs being supplied with the tool (special compliance forces upon request)

ESR 1 000 FW

- For **non-lubricated use**, practically wearless, with floating spindle support
- Easy to service turbine motor
- Ideal for plastics and other materials which require non-lubricated and clean air

ESR 1 000, ESR 855, ESR 551

- The force of compliance can be set and adjusted precisely by using a **precision pressure regulator** (see page 68).

RoboCut | Robust spindles Precise deburring and milling



Technical data

RoboCut		ESR 350	ESR 280	ESR 200	ESR 170
<i>Mounting</i>					
Order-No.		29942-16-5	29944-53-5	60011-88-5	29940-07-5
Compressed air		lubricated	lubricated	lubricated	lubricated
Free speed	rpm	35 000	28 000	20 000	15 000
Motor power	Watt	300	380	380	800
Radial compliance		± 4°	± 4°	± 4°	± 4°
Exhaust air		to the front	to the front	to the front	to the front
ER collet included	mm	6	6	6	8
ER collets available	mm	3 4 5	3 5 8 10	3 5 8 10	3 5 6 10
Compliance force range		10–55 N	10–55 N	12–55 N	25–110 N
Compliance force max.*		200 N	200 N	200 N	200 N
Direction of rotation		clockwise	clockwise	clockwise	clockwise
Noise level	dB(A)	79	80	78	82
Air consumption	l/sec	8.3	11.5	12.5	15.0
Weight	kg	1.80	1.90	1.90	5.15
Connection air supply (hose)	∅ mm, inside/outside	6 8	6 8	6 8	6 8
Accessories supplied		wrench	wrench	wrench	wrench

Power and free speed at 6 bar operating pressure. Compressed air quality: lubricated (2–3 drops per minute). Subject to technical alterations.

- Broad revolution speed and power ranges for different deburring tasks
- Easy to mount horizontally or vertically onto a tool stand due to cuboid housing
- Easy to mount to a robot arm by thread connection
- Highest true running accuracy, load capability and best deburring results due to paired ball bearings
- Type ESR 170 for the most powerful milling and deburring tasks
- Compliance forces are controlled by air pressure or via optional spring package

Use in CNC machines

The ESR models can be integrated into CNC machines using SK-, MK-, HSK-cones. The compliance force is preset via spring packages according to customers' needs.

RoboCut | Flexible trouble shooters

Brushing



ESR 50

ESR 50 AX25, with various exemplary brushes

Technical data

RoboCut		ESR 50	ESR 30	ESR 50 AX25	ESR 30 AX25
Order-No.		29940-05-5	29940-03-5	60001-34-5	60001-35-5
Ideal use		brushing	brushing	brushing	brushing
Compressed air		lubricated	lubricated	lubricated	lubricated
Free speed	rpm	5 000	3 000	5 000	3 000
Motor power	Watt	380	380	380	380
Radial compliance		± 4°	± 4°	—	—
Axial compliance	mm	—	—	25	25
Exhaust air		to the front	to the front	to the front	to the front
ER collet included	mm	6	6	6	6
ER collets available	mm	3 5 8 10	3 5 8 10	3 5 8 10	3 5 8 10
Compliance force range		30–150 N	30–150 N	25–1 000 N	25–1 000 N
Compliance force max.*		200 N	200 N	—	—
Direction of rotation		clockwise	clockwise	clockwise	clockwise
Noise level	dB(A)	80	80	80	80
Air consumption	l / sec	8.3	8.3	8.3	8.3
Weight	kg	4.75	4.75	6.42	6.42
Connection air supply (hose)	∅ mm, inside /outside	10 12	10 12	10 12	10 12
Accessories supplied		wrench	wrench	wrench	wrench

Power and free speed at 6 bar operating pressure. Compressed air quality: lubricated (2–3 drops per minute). Subject to technical alterations.

* Various pre-adjusted pressing forces on request.

- Maximum axial compliance of 25 mm
- Use of non-lubricated air motors for low wear and long life time
- Compliance forces are controlled by air pressure or via optional spring package

Please see page 68 for recommended precision pressure regulators and manometers for the machines with axial compliance.

Further revolution speeds and power classes upon request.



ESR 38-520



RBS 38-520 AX25



RWBS 38-520

Technical data

RoboCut		ESR 38-520	RBS 38-520 AX25	RWBS 38-520
Order-No.		29948-43-5	60001-33-5	60000-69-5
Ideal use		drilling reaming	countersinking	countersinking
Compressed air		lubricated	lubricated	lubricated
Free speed	rpm	520	520	520
Motor power	Watt	380	380	380
Radial compliance		± 4°	—	± 4°
Axial compliance	mm	—	25	—
Exhaust air		to the front	to the front	to the front
ER collet included / connection	mm	6	6	1/4"– 6 kt.
Radial compliance of coupling		—	± 7°	—
Radial off-set of coupling	mm	—	± 0,5	—
ER collets available	mm	3 5 8 10	—	—
Compliance force range		18–75 N	25–1 000 N	10–70 N
Compliance force max.*		200 N	—	200 N
Direction of rotation		clockwise	clockwise	clockwise
Noise level	dB(A)	80	80	77
Air consumption	l / sec	8.3	8.3	8.3
Weight	kg	4.90	6.67	5.50
Connection air supply (hose)	∅ mm, inside /outside	10 12	10 12	10 12
Accessories supplied		wrench	wrench	wrench

Power and free speed at 6 bar operating pressure. Compressed air quality: lubricated (2–3 drops per minute). Subject to technical alterations.

- ESR 38-520 for reaming and deburring of drill holes and intersections
- RBS 38-520 AX25 with axial and radial compliance
- Slim tool design: Ideal for difficult to access areas (e. g. pipes or complex casts with small space)
- Compliance forces are controlled by air pressure or via optional spring package

Please see page 68 for recommended precision pressure regulators and manometers for the machines with axial compliance.

Further revolution speeds and power classes upon request.

RoboCut | Flexible trouble shooters

Filing



RF 110



FRV 100

Technical data

RoboCut		RF 110	FRV 100
Order-No.		60001-30-5	60026-94-6
Ideal use		filing	filing
Compressed air		lubricated	lubricated
Frequency	Hz	150	150
Number of blows	rpm	9 000	9 000
Stroke max.	mm	8	8
Radial compliance		± 4°	—
Exhaust air		to the front	to the front
Tool holder round Ø	mm	6	6
Compliance force range		18–75 N	—
Compliance force max.		200 N	—
Noise level	dB(A)	77	77
Air consumption	l/sec	1.05	1.05
Weight	kg	4.7	1.0
Connection air supply (hose)	Ø mm, inside / outside	10 12	G 1/4"
Accessories supplied		wrench	wrench

Power and free speed at 6 bar operating pressure. Compressed air quality: lubricated (2–3 drops per min.).
Subject to technical alterations.

- RoboFile: robust filing machine RF 110 to deburr casts and machined parts or sand cores for foundries
- Very low vibration level of 2.0 m/s²: high precision due to smooth running
- Compliance forces are controlled by air pressure or via optional spring package

Files Ø shaft 6.0 mm

Form	■	■	▲	■	●
Cut 1 Order-No.	9 376 900	9 376 901	9 376 902	9 376 903	9 376 904
Cut 0 Order-No.	9 376 912	—	—	—	—
Cut 1 Width × depth	mm 12.3 × 6.3	8.0 × 8.0	9.0 × 9.0	12.0 × 6.0	Ø 6.0
Cut 0 Width × depth	mm 12.0 × 7.0	—	—	—	—
Useable length	mm 80	80	80	80	80
Ø shaft	mm 6.0	6.0	6.0	6.0	6.0

Dimensions Pneumatic spindles

Page 40 | EST 1000 ZG

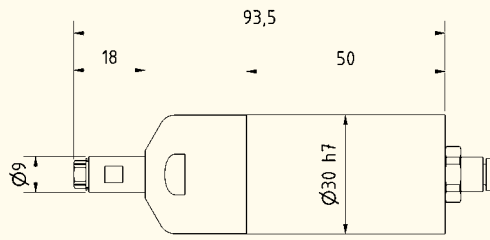

Page 40 | EST 1000 K and EST 650 K

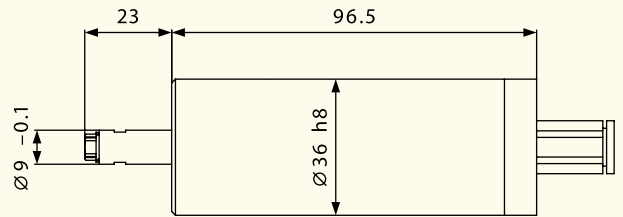

Page 40 | EST 450 K

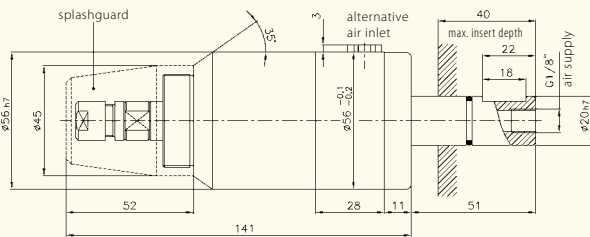

Page 41 | ES 852 ZG

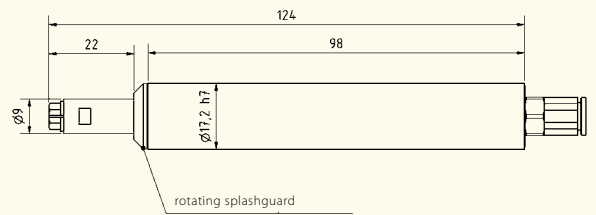

Page 41 | ES 550 ZG

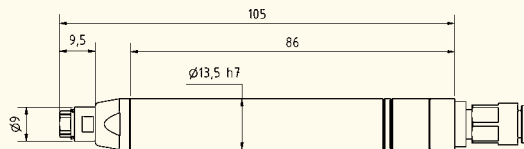

Page 42 | ES 350 ER and ES 450 ER

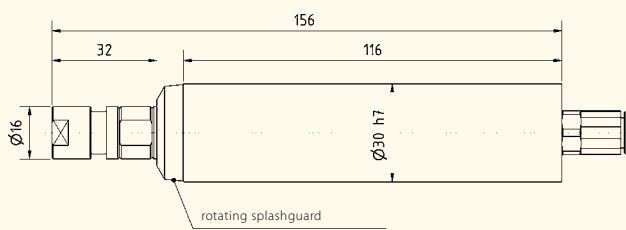

Page 42 | ES 450 ZG and ES 350 ZG

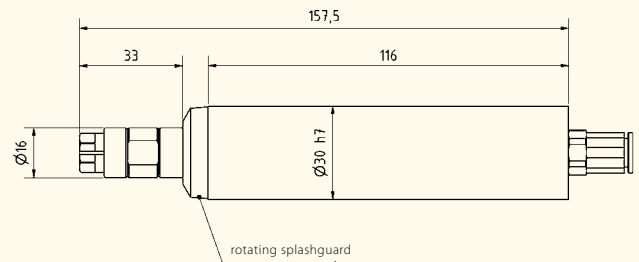

Page 43 | ES 280 ZG

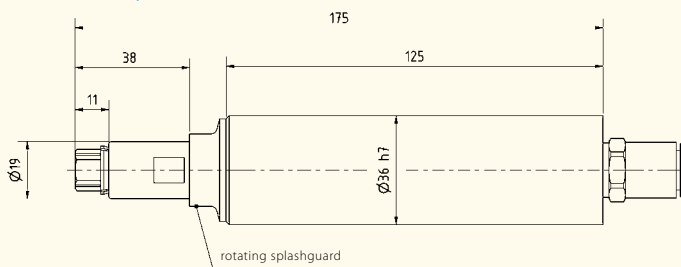

Page 43 | ES 280 ER

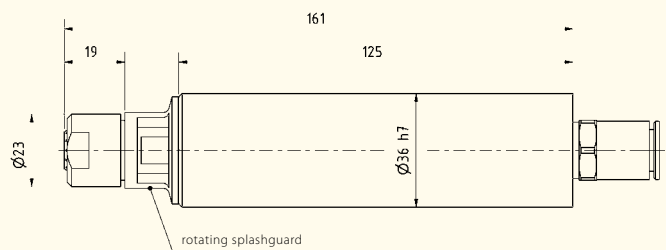

Dimensions

Pneumatic built-in motors

Page 43 | ES 200 ZG

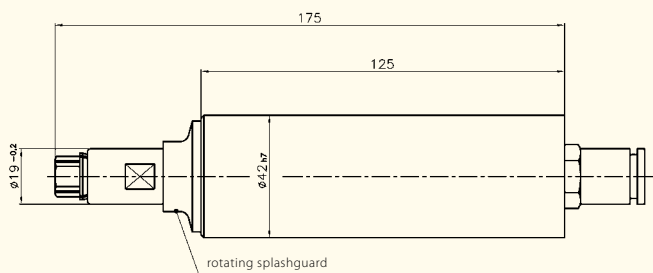

Page 43 | ES 200 ER

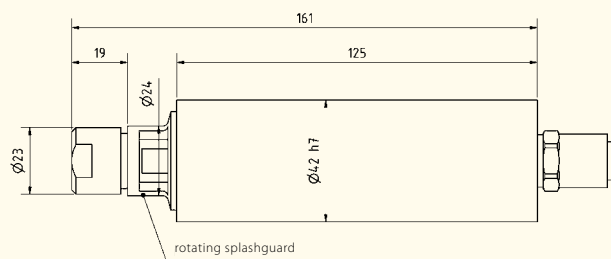

Page 43 | ES 170 ZG

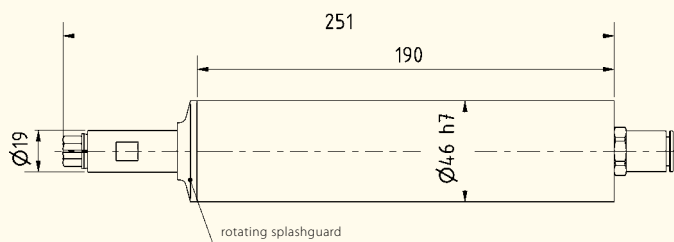

Page 43 | ES 170 ER

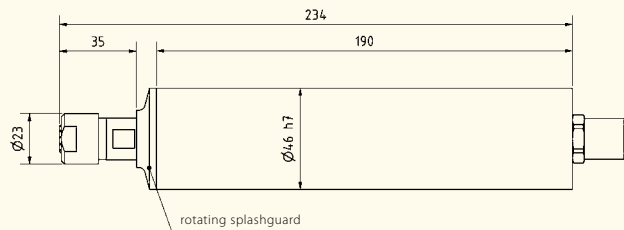

Page 44 | EBM 19000 S to 2400 S, EBM 19000 SL to 2900 SL

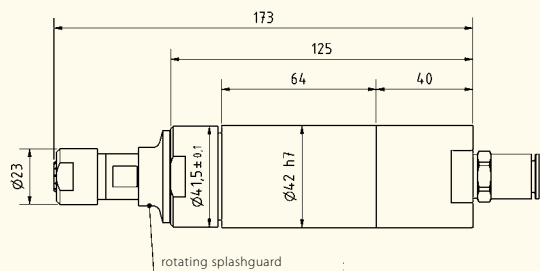

Page 44 | EBM 1200 S

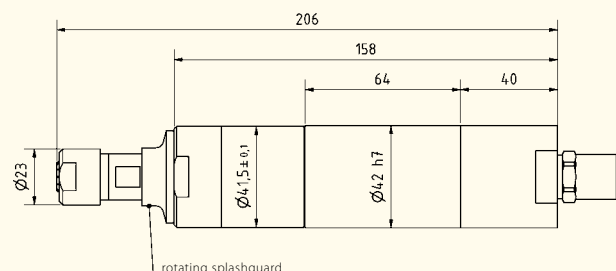

Page 45 | EBM 38-5200 B, 38-2900 B, 38-2400 B

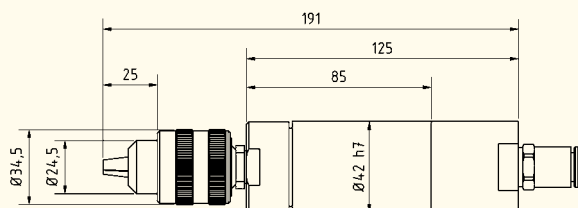

Page 45 | EBM 38-1200 B

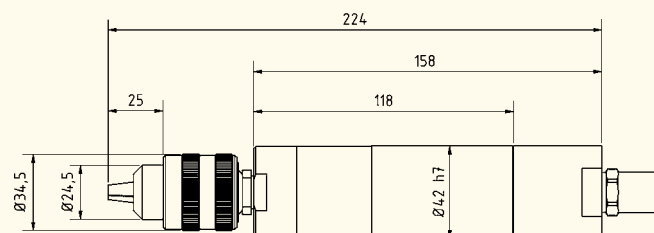

Page 45 | EBM 5000 B and EBM 3500 B

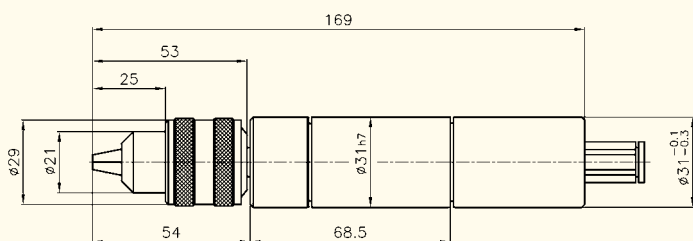

Page 46 | EBMU 23-4000 B and EBMU 23-2000 B

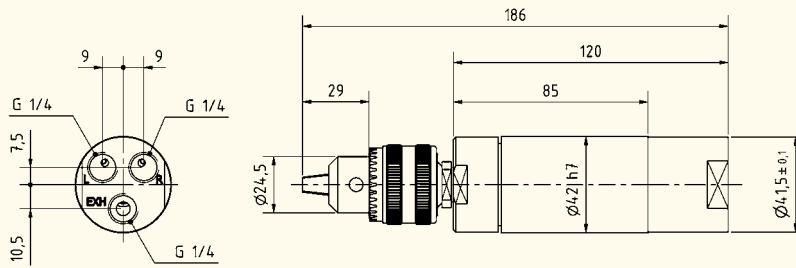

Page 46 | EBMU 23-1000 B

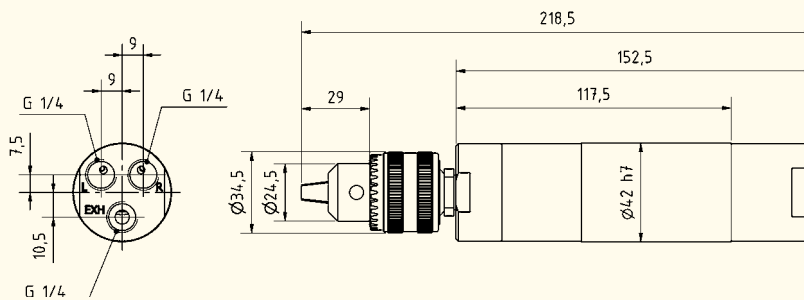

Page 46 | EBMU 40-4800 B, EBMU 40-3400 B, EBMU 40-3000 B

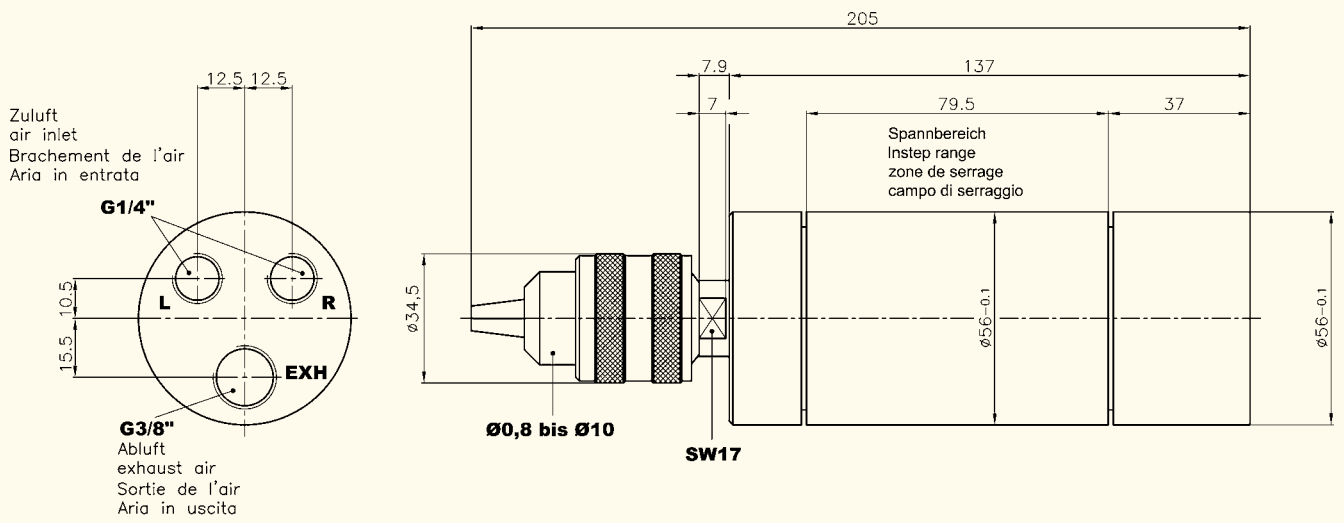

Dimensions

Pneumatic chamfering motors | RoboCut

Page 47 | EBS 504 ZG

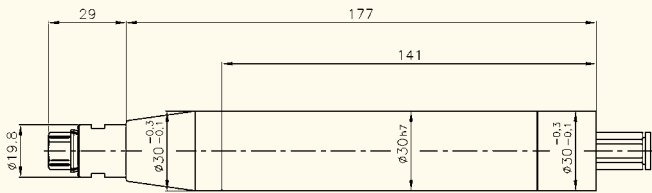

Page 47 | EBS 520 ER

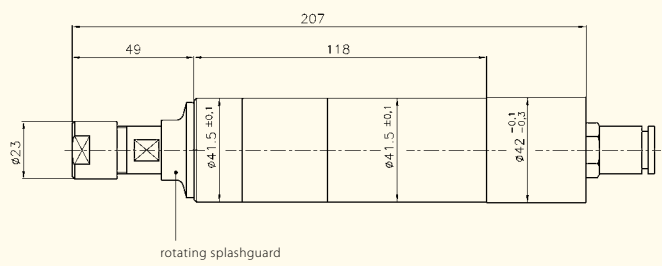

Page 47 | EBS 520 WK

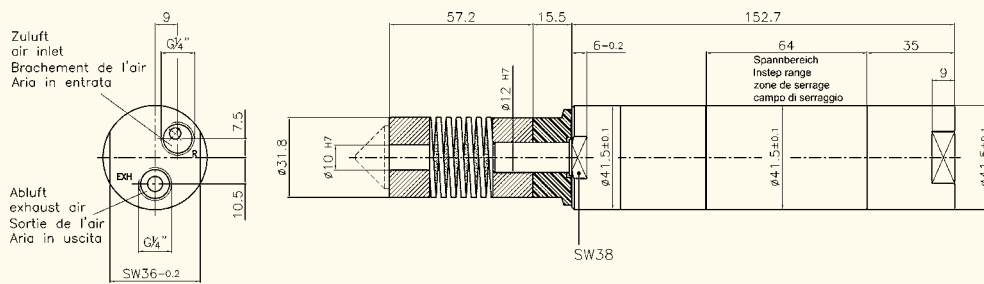

Page 47 | EWBS 38-520

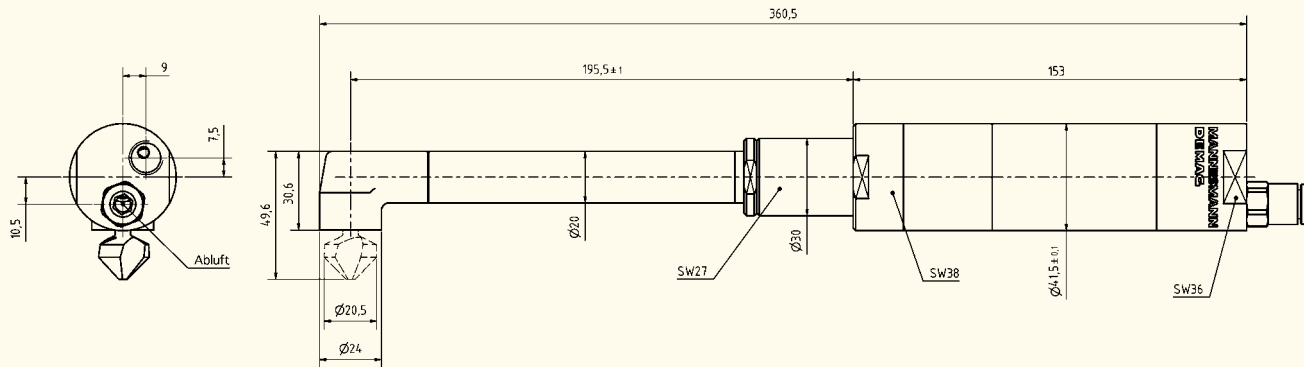

Page 49 | ESK 1000 W20

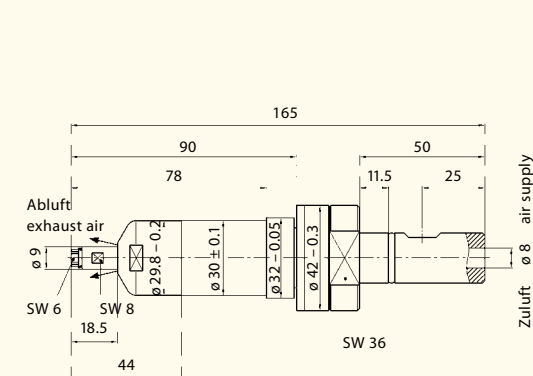

Page 49 | ESK 350 W20

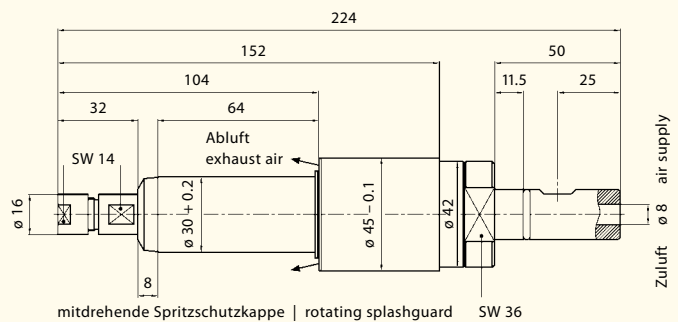

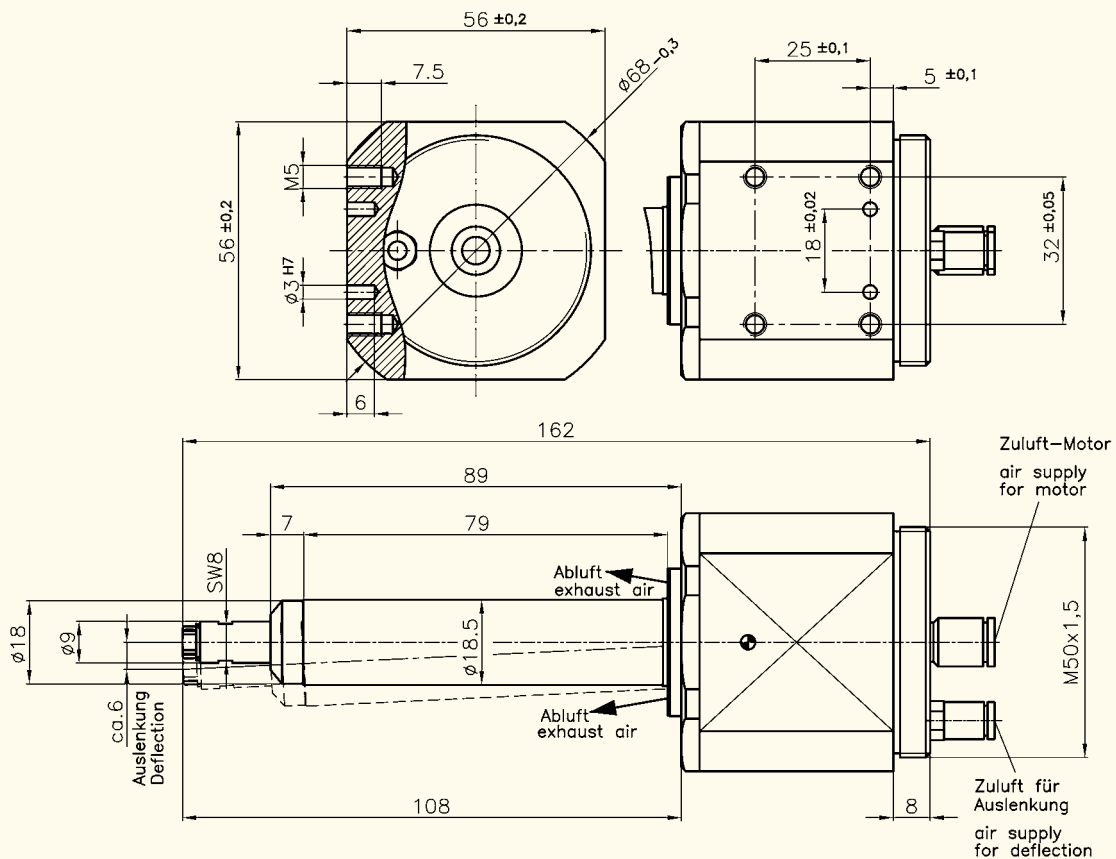
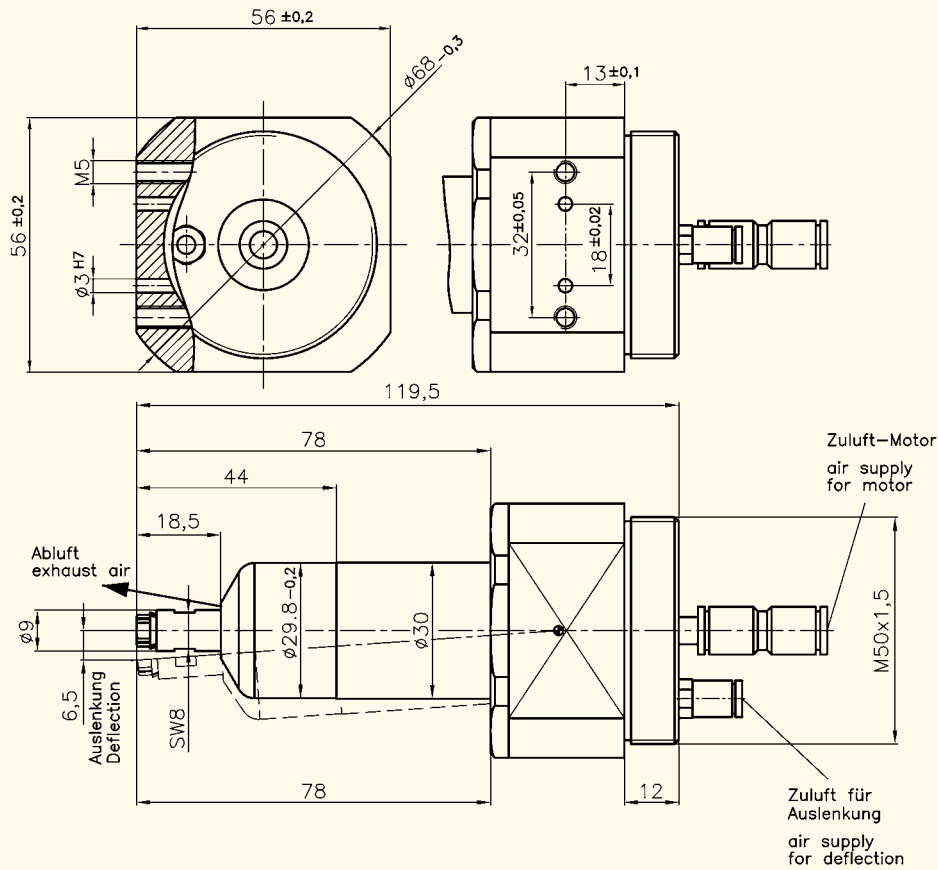

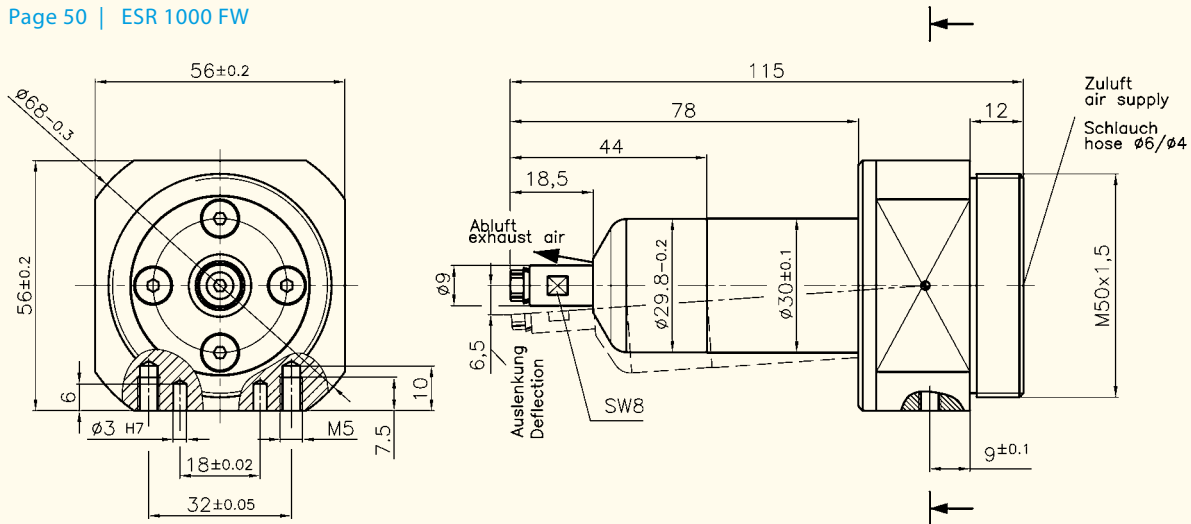
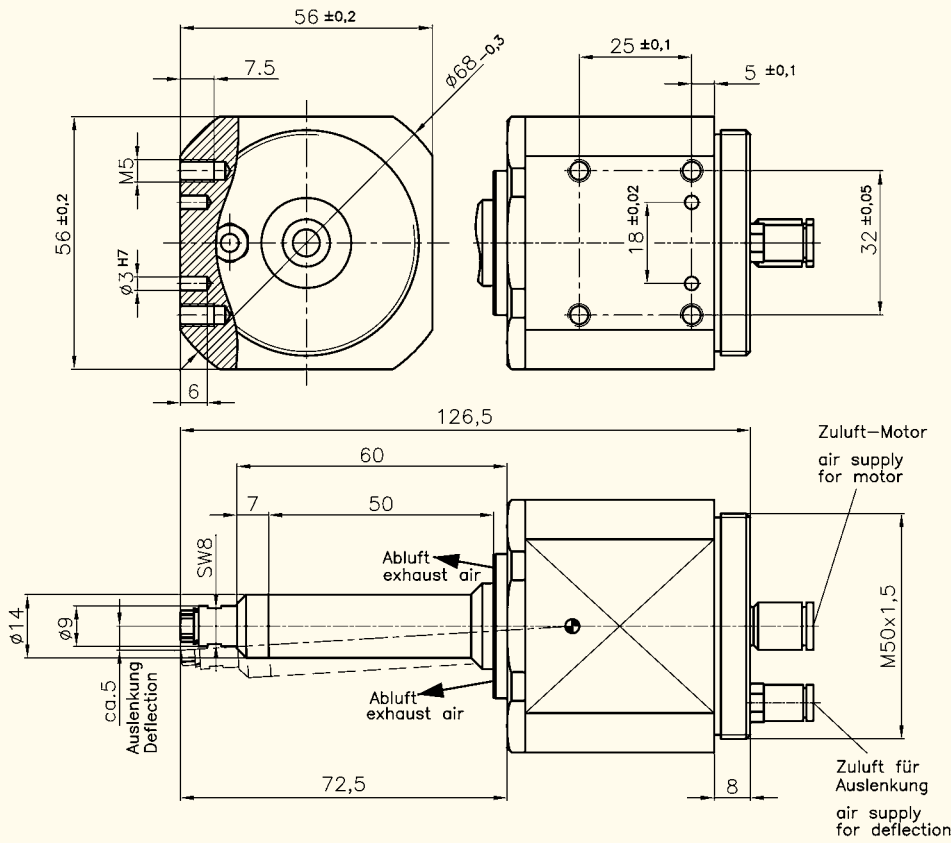

Dimensions RoboCut

Page 51 | ESR 350

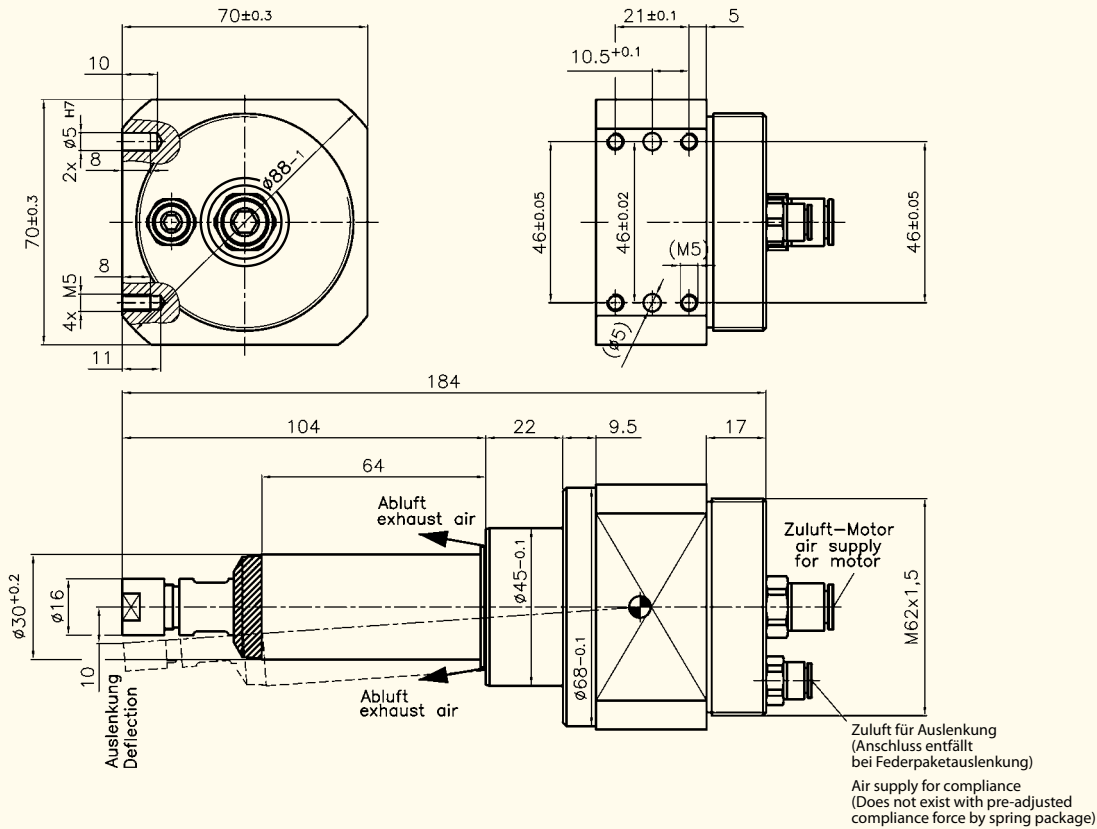

Page 51 | ESR 280

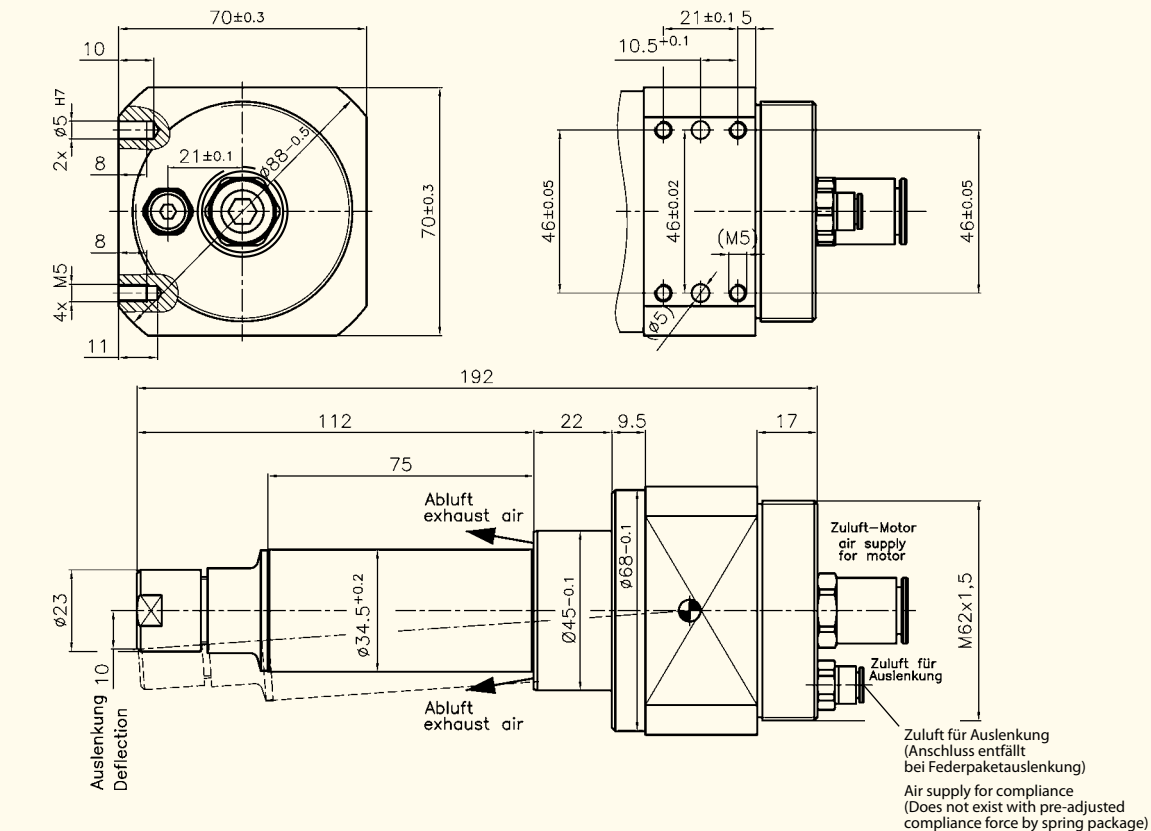

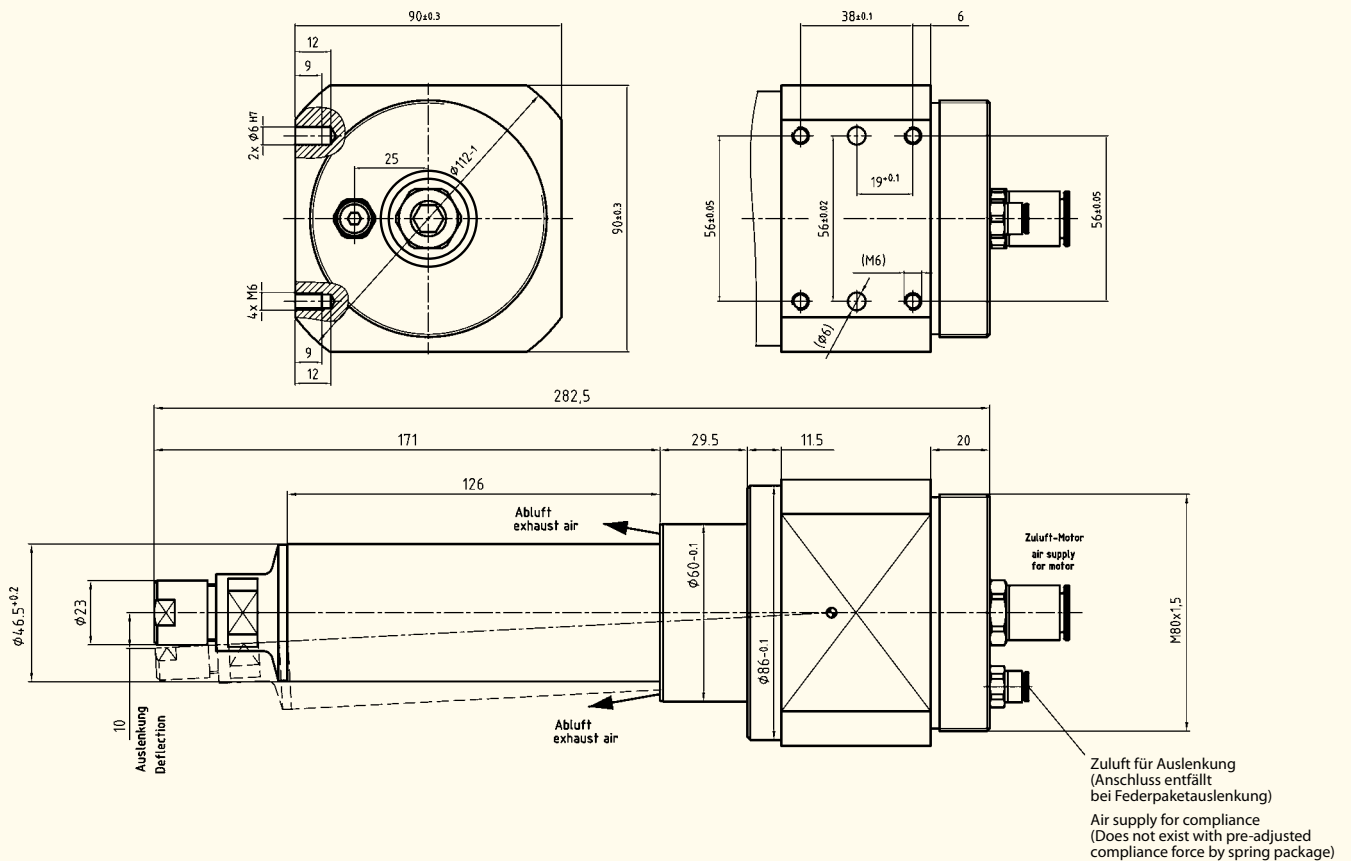
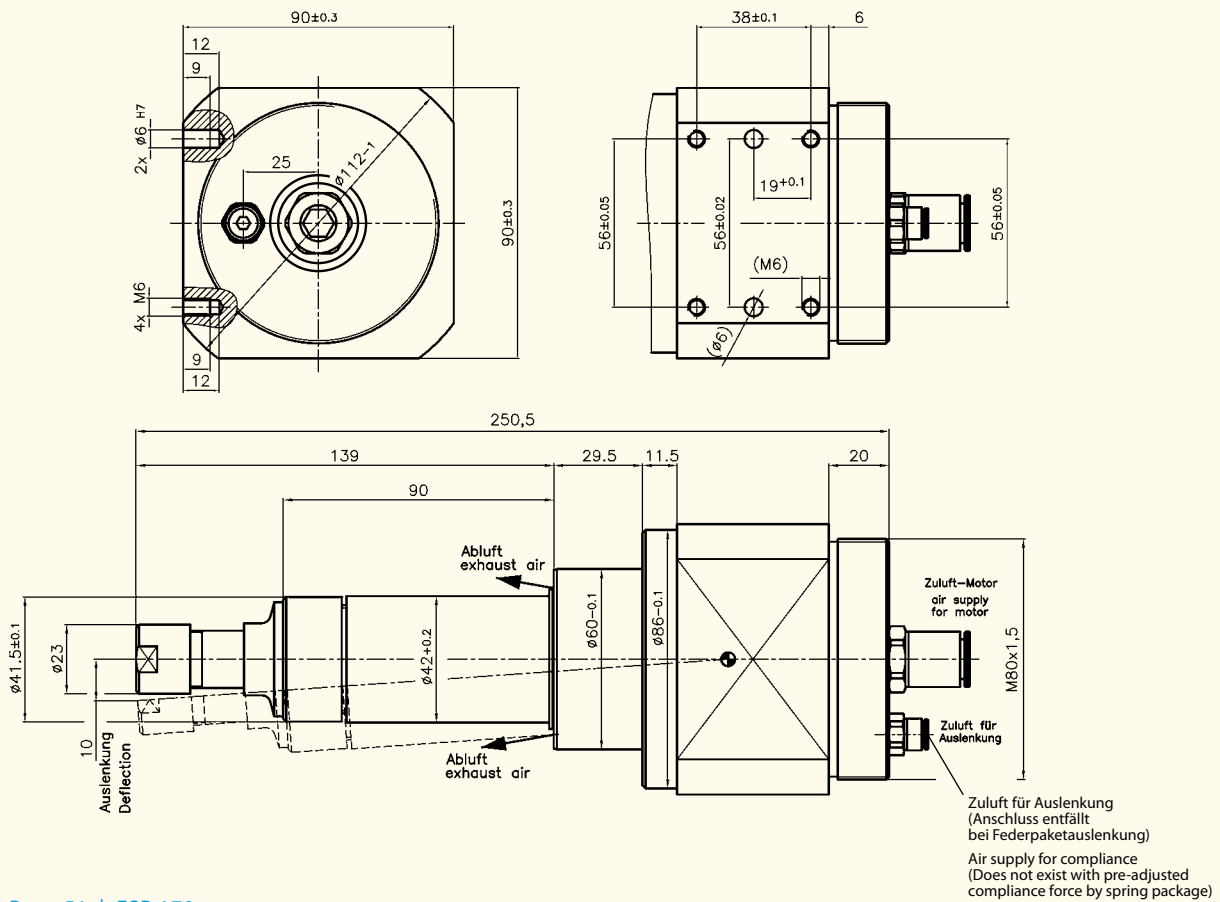

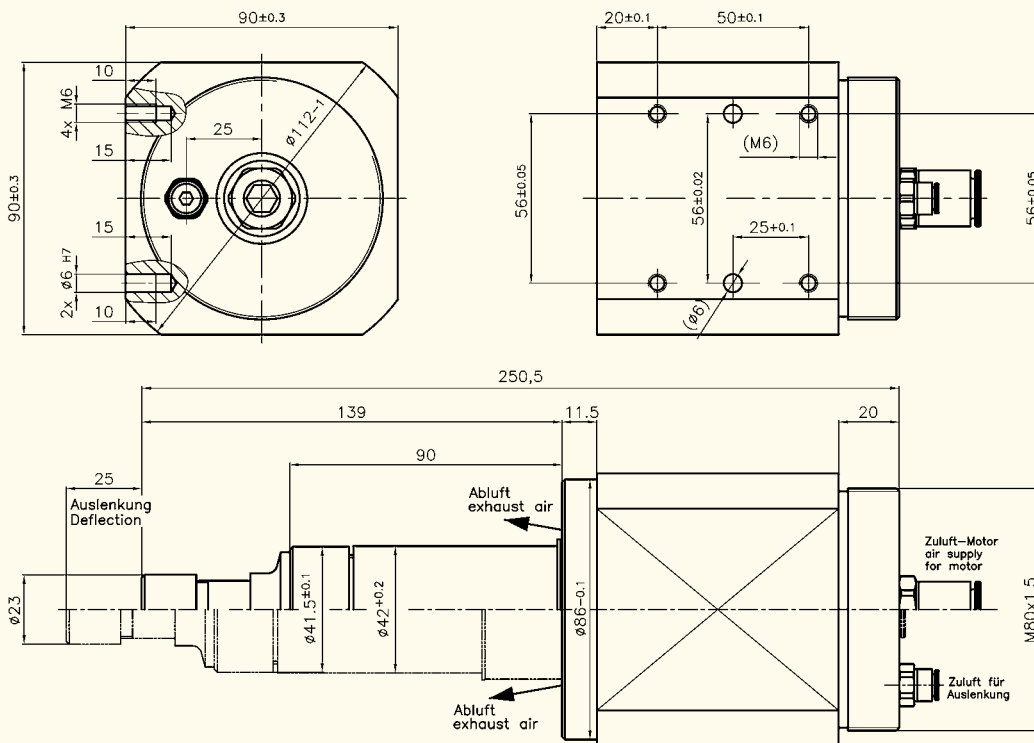
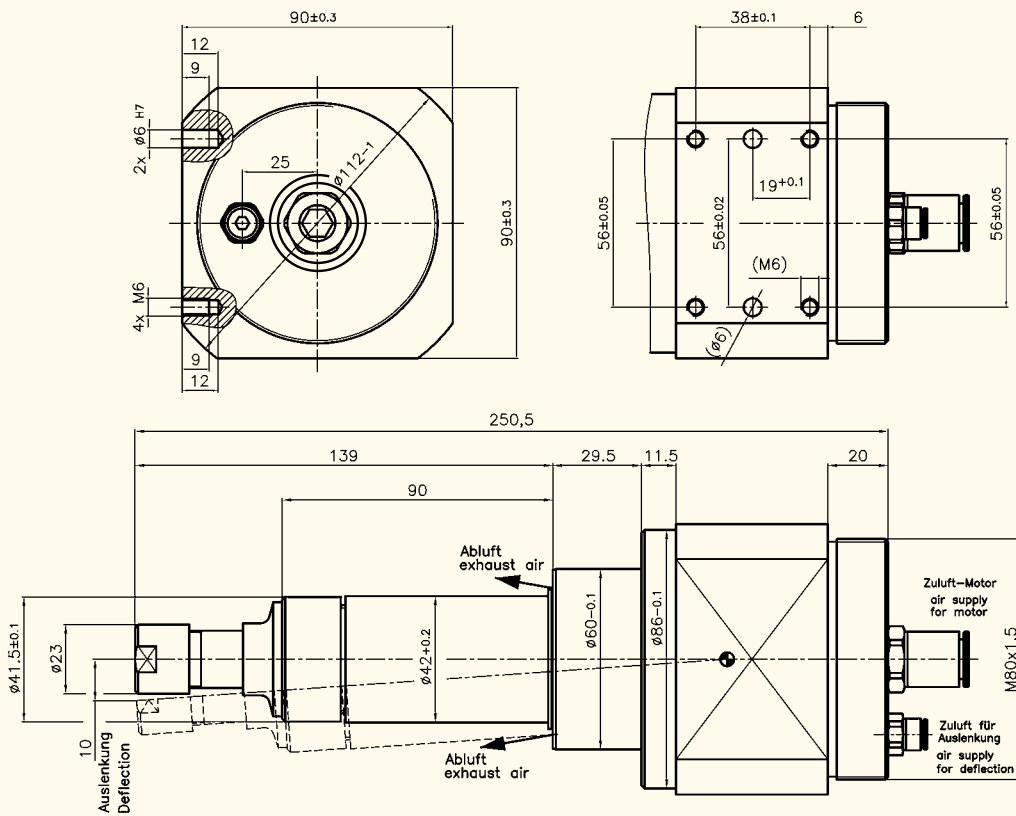

Page 53 | ESR 38-520

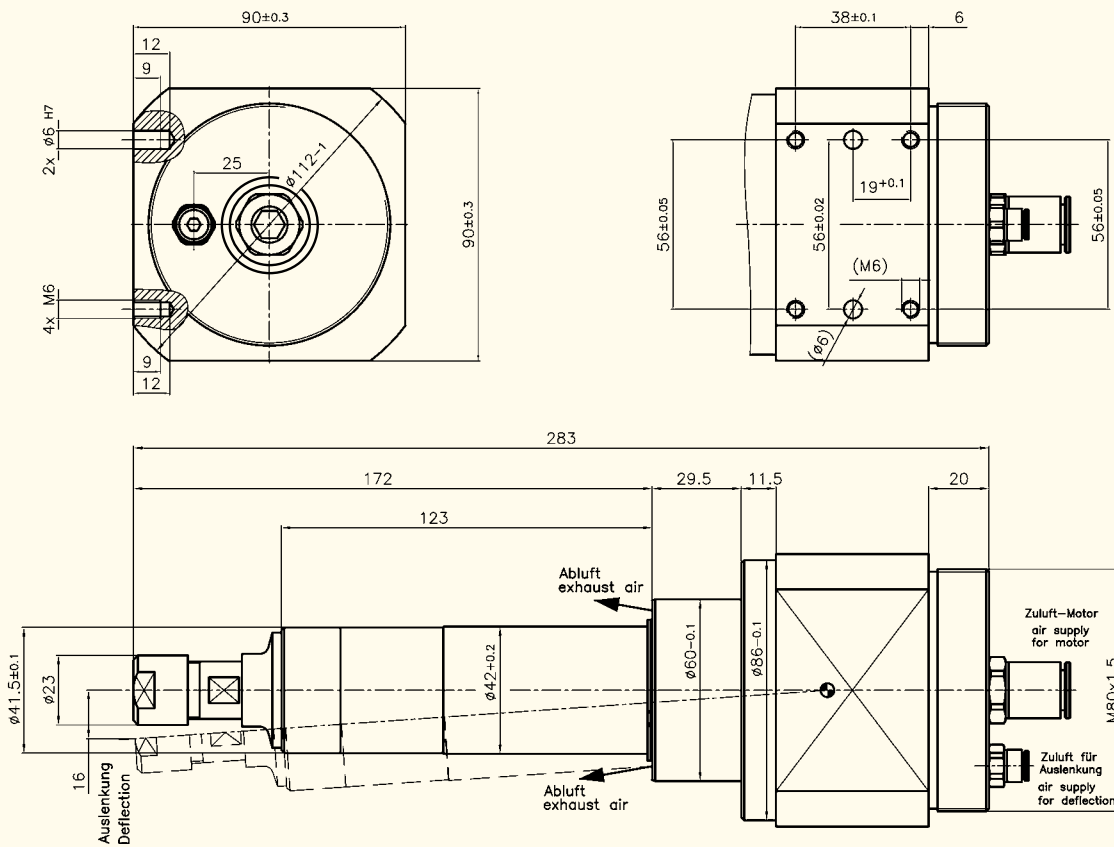

Page 53 | RBS 38-520 AX25

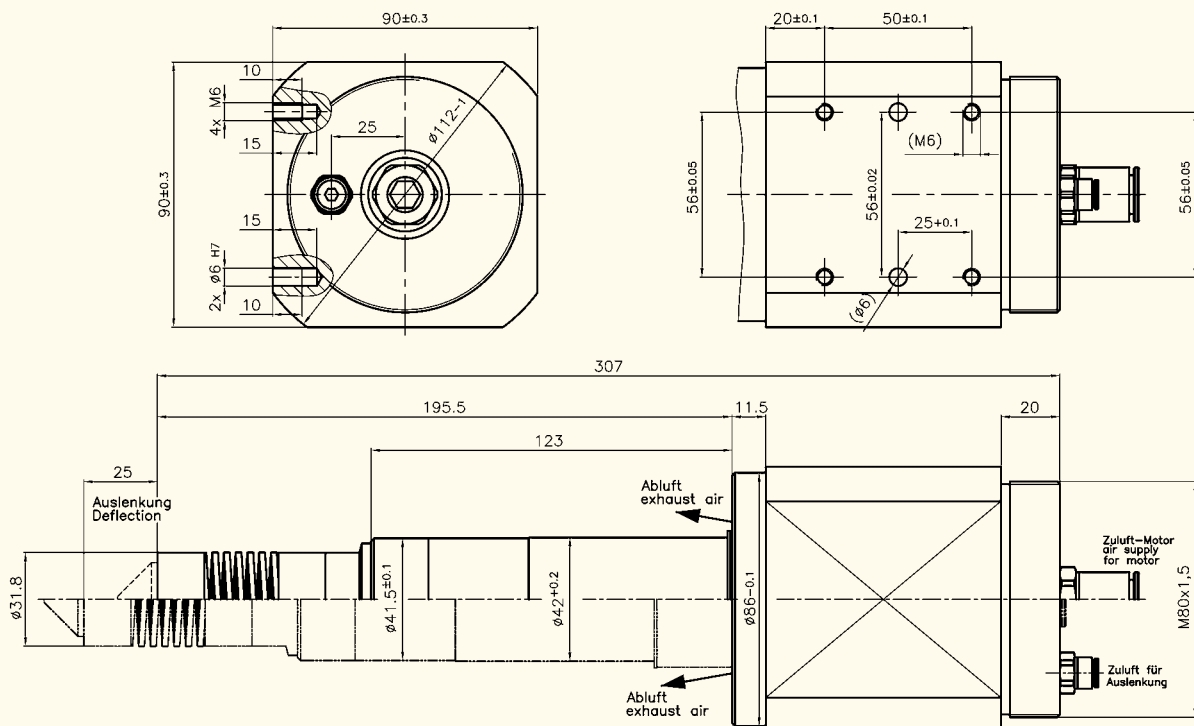

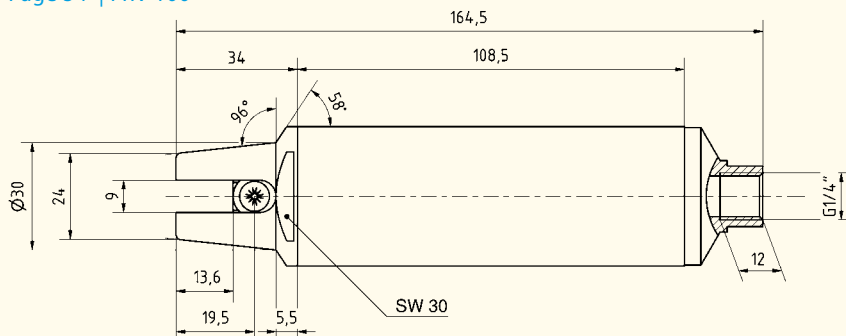
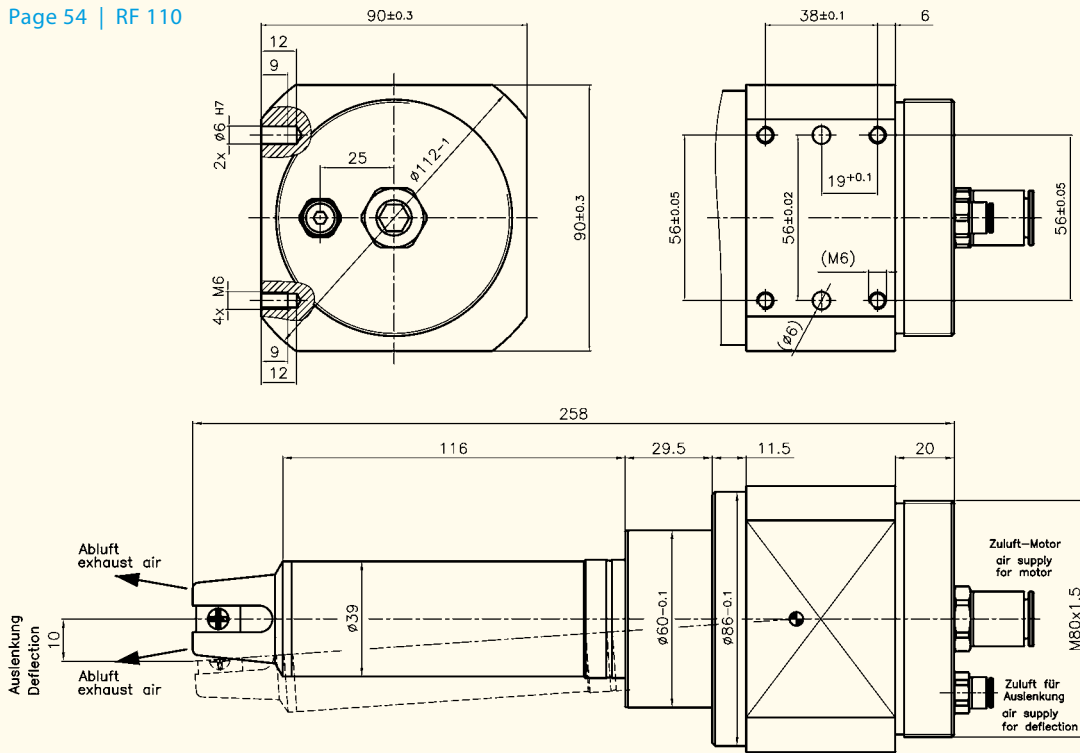
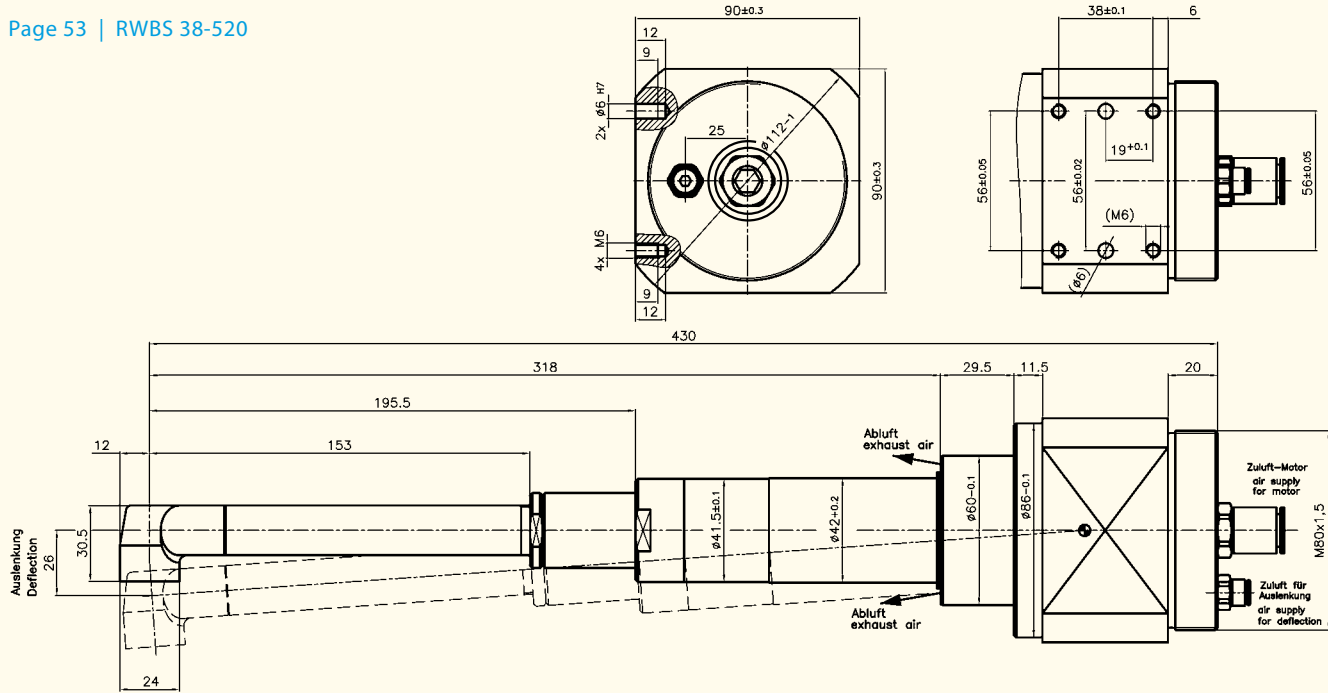

Examples



Spindles | ZG collets

Clamping range \varnothing (mm|")

Types	page	1.0	1.5	2.0	2.5	3/32"	3.0	1/8"
EST 1000 ZG	40	9 369 912	9 369 913	9 369 914	9 369 915	9 369 916	9 369 825	9 369 917
EST 1000 K	40	9 369 912	9 369 913	9 369 914	9 369 915	9 369 916	9 369 825	9 369 917
EST 650 K	40	9 369 912	9 369 913	9 369 914	9 369 915	9 369 916	9 369 825	9 369 917
ES 852/550 ZG	41	9 369 912	9 369 913	9 369 914	9 369 915	9 369 916	9 369 825	9 369 917
ESK 1000 W20	49	9 369 912	9 369 913	9 369 914	9 369 915	9 369 916	9 369 825	9 369 917

Types	page	3.0	4.0	5.0	6.0	8.0	1/4"	10.0
ES 450/350 ZG	42	9 369 841	9 369 846	9 369 847	9 369 826	9 369 843	9 369 872	—
ES 280-170 ZG	43	—	—	9 369 816	9 369 837	9 369 818	9 369 987	9 369 817

Spindles | ER collets

Types	page	3.0	4.0	5.0	6.0	8.0	10.0
EST 450 K	40	9 369 853	9 369 849	9 369 838	9 369 832	—	—
ES 450/350 ER	42	9 369 853	9 369 849	9 369 838	9 369 832	—	—
ES 280-170 ER	43	9 369 855	—	9 369 850	9 369 839	9 369 842	9 369 852
ESK 350 W20	49	9 369 853	9 369 853	9 369 838	9 369 832	—	—

Motors | ZG collets

Types	page	3.0	4.0	5.0	6.0	8.0	1/4"	10.0
EBS 504 ZG	47	—	—	9 369 816	9 369 837	9 369 818	9 369 987	9 369 817

Motors | ER collets

Types	page	3.0	4.0	5.0	6.0	8.0	10.0
every EBM	47	9 369 855	—	9 369 850	9 369 839	9 369 842	9 369 852
EBS 520 ER	48	9 369 855	—	9 369 850	9 369 839	9 369 842	9 369 852

Motors | Drill chucks, drill chuck keys

Types	page	drill chuck	drill chuck key	quick change drill chuck
every EBM 38-...	45	9 376 022	9 369 811	9 369 988
EBM 5000 B EBM 3500 B	45	9 376 019	9 369 811	9 369 990
every EBMU 23-...	46	9 369 785	9 369 811	9 376 040
every EBMU 40-...	46	9 369 788	9 376 018	—

Accessories

Accessories



RoboCut | ZG collets

Clamping range \varnothing (mm|")

Types	page	1.0	1.5	2.0	2.5	3/32"	3.0	1/8"
ESR 1 000/1 000 FW	50	9 369 912	9 369 913	9 369 914	9 369 915	9 369 916	9 369 825	9 369 917
ESR 855/855 FW	50	9 369 912	9 369 913	9 369 914	9 369 915	9 369 916	9 369 825	9 369 917
ESR 551/551 FW	50	9 369 912	9 369 913	9 369 914	9 369 915	9 369 916	9 369 825	9 369 917

RoboCut | ER collets

Types	page	3.0	4.0	5.0	6.0	8.0	10.0
ESR 350	51	9 369 853	9 369 849	9 369 838	9 369 832	—	—
ESR 280	51	9 369 855	—	9 369 850	9 369 839	9 369 842	9 369 852
ESR 230	51	9 369 855	—	9 369 850	9 369 839	9 369 842	9 369 852
ESR 170	51	9 369 855	—	9 369 850	9 369 839	9 369 842	9 369 852
ESR 50/30	52	9 369 855	—	9 369 850	9 369 839	9 369 842	9 369 852
ESR 50 AX 25	52	9 369 855	—	9 369 850	9 369 839	9 369 842	9 369 852
ESR 30 AX 25	52	9 369 855	—	9 369 850	9 369 839	9 369 842	9 369 852
ESR 38-520	53	9 369 855	—	9 369 850	9 369 839	9 369 842	9 369 852

Precision pressure regulator

Types	page	connection thread	working pressure bar adjustable	Order-No. Regulator	Order-No. Manometer
ESR 50 AX 25	52	G 1/4"	0,05–2 bar	60001-37-3	60001-38-3
ESR 30 AX 25	52	G 1/4"	0,05–2 bar	60001-37-3	60001-38-3
RBS 38-520 AX 25	53	G 1/4"	0,05–2 bar	60001-37-3	60001-38-3



Regulator with Manometer

Oil trap unit

Order No.	60025-98-6	
Connection thread	G 1/2"	
Air flow	l / min	2 500
Weight	kg	0.74
max. oil amount at exit	mg / m ³	0.01
Filter efficiency	99.99%	
Noise dampening	up to 40 dB(A)	

- Design: Filter noise dampener
- For vertical installation
- Working pressure min. / max.: 0 / 10 bar
- For compressed air
- Temperature range min. / max.: – 10 / + 60 °C
- Aluminium housing
- Filter end cap: steel
- Reservoir and oil drip cup: Polyoxymethylen



Oil trap unit